

54WS094

EUROPA TOE-IN FOR FRONT AND REAR WHEELS

Are your tires wearing out too fast or does your machine handle in a less than fantastic manner? When was the last time you checked the toe-in of both your front and rear wheels? That long huh? So you bring your Europa in for wheel alignment. If all goes well your front wheels may be adjusted properly, however your rear wheels probably will not be checked unless you specifically request it, even then few people know how to adjust the rear wheels.

Just what is toe-in? It is the distance that the front of the wheels point inward. Toe-out is the distance the front of the wheels point outward (in the direction of vehicle motion).

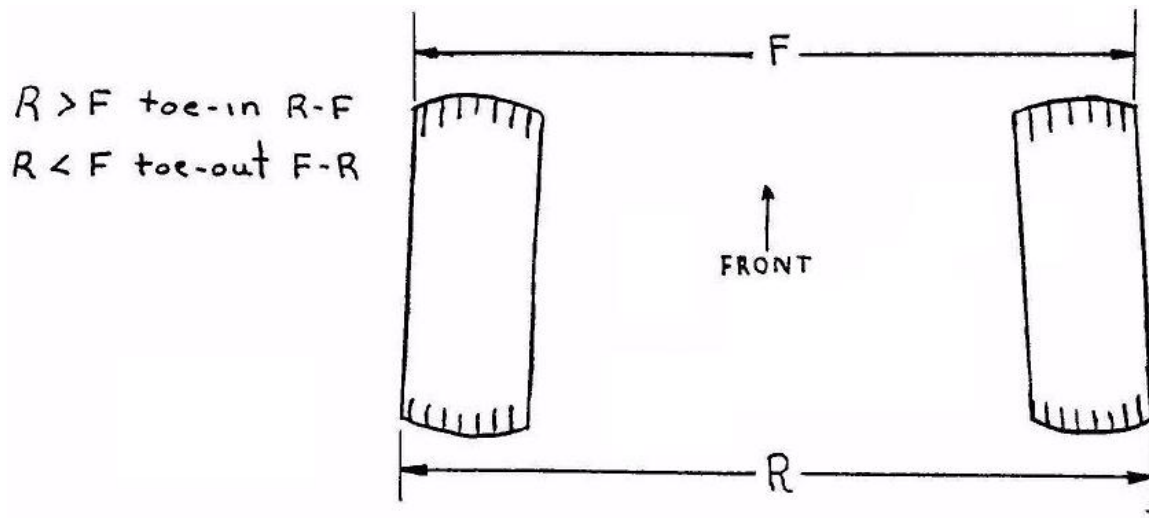

Consider the condition when your rear wheels are toed out $\frac{1}{2}$ ". For every 24 miles you drive the wheels try to move sideways $\frac{1}{4}$ mile, each in the opposite direction. Thus the wheels are dragged sideways. This results in poor handling and rapid tire wear.

Unless your service man is on his toes the job that is done can probably be done better, faster, and cheaper by you. But you do need a special tool to make things simple. However the cost may shock you. You can obtain a reasonable, although light weight and light duty unit, for not much more than a wheel alignment cost. J. C. Whitney has a good unit (circa \$20 in 1978) which I have used on four vehicles we have for three years with excellent results. Check around for other sources but don't buy a costly 'professional' model or the cheapest piece of junk you can find which may not be accurate and even fall apart. The only thing to look for is a removable or foldable end leg, since almost none of the units will fit under your Lotus with the leg in use.

Now you're almost ready, but what to set the toe-in to? Check your shop manual. For Twin Cam and Specials: Front toe-in $\frac{1}{16}$ to $\frac{3}{16}$ " Rear toe-in $\frac{1}{8}$ to $1\frac{1}{4}$ ". For earlier Europas: Front same Rear Zero to $\frac{3}{16}$ ".

To measure the toe-in you must have the wheels straight and may have to remove the gauge leg. Locate two bricks, short boards, soup cans, what have you. Use these in place of the leg and at the hand held end. Now you must zero the gauge. This is done under the back or in front of the wheel depending upon the gauge. This is easy to check, for if moving the gauge lever out from the car gives a 'toe-out' you zero under the rear of the tire; if moving it out gives a 'toe-in' you zero under the front of the tire. Once you have the gauge set to zero and locked, gently replace the unit under the other side of the tire, using the same 'modified legs'. You now read directly the toe-in or toe-out.

To adjust the front wheels locate the end of the steering linkages. Loosen but do not remove the clamp on the bellows and loosen the locking nut (shown below). Repeat this on the other side of the vehicle. Rotate BOTH tie rods (the ends of the steering linkages) the same amount. This is done by hand or gently with grips (pliers etc.). Now move the vehicle forward and backwards a couple of times so that the wheels turn 1 revolution and the tires move to the new position. Recheck the toe-in. If not correct readjust as necessary. When you have two readings that are correct (IMPORTANT: MOVE VEHICLE IN A STRAIGHT LINE BEFORE MEASURING TOE-IN EACH TIME) tighten the locknuts carefully so as not to move the tie rods and retighten the bellows clamp. Now take one final check of the toe-in (YOU MUST CHECK AND ZERO THE GAUGE EACH TIME). You have done a better than professional job.

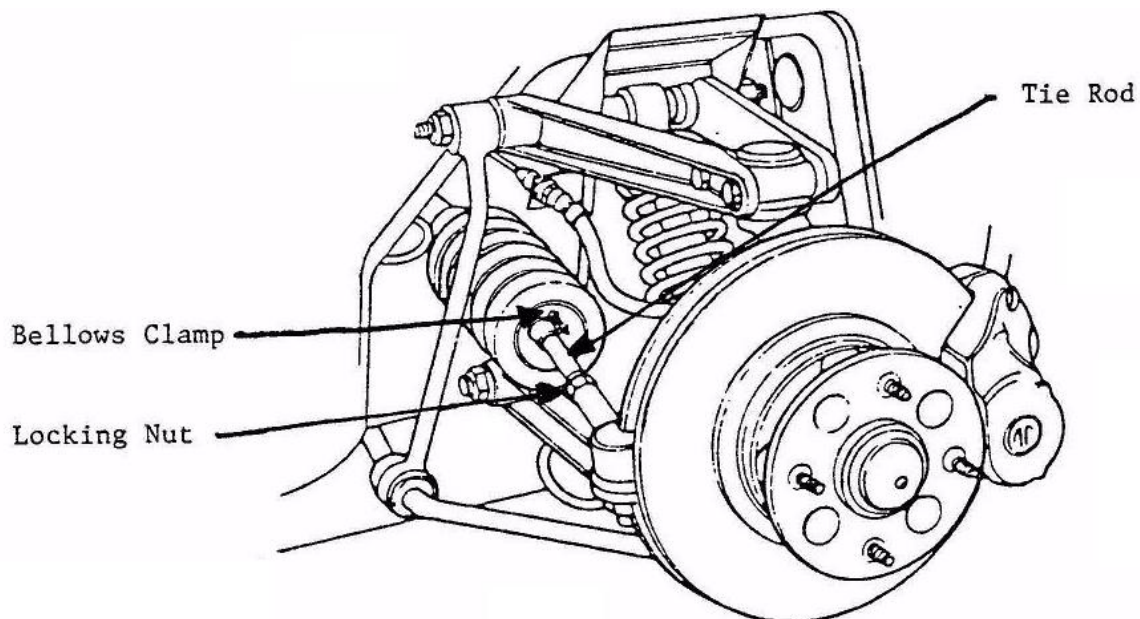

To adjust the rear wheels locate the radius arm pivot ends (shown on the next page) and the nut and bolt that attaches it. Between the radius arm and the frame are spacer washers. Removing the washers will increase toe-in; adding washers will reduce toe-in (increase toe-out). Retighten the bolt and nut and check toe-in. On early non-TC Europas, prior to Chassis No. 2414, it may be necessary to replace the rubber insulators on the inside of the chassis using a reinforcing plate Lotus Part No. 054 A 0251. If anyone has this plate or obtains one, please pass on the dimensions and any hints. If your lower link bushings, universal joints, or bearings are worn it will affect the toe-in, so assure that everything is in proper order.

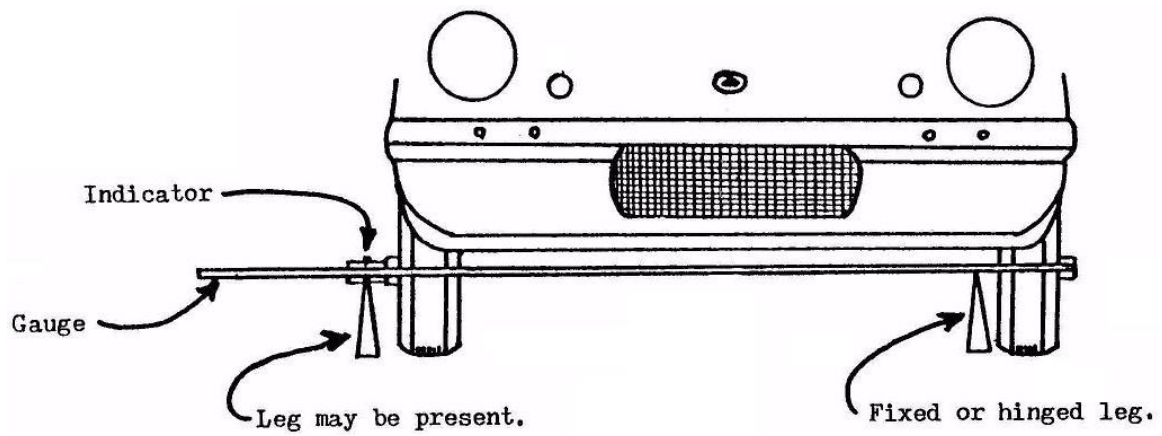

Gauge is shown in front of the front wheels, clearance will be less towards the center of the car and it may be necessary to remove the legs to lower the gauge. It is important that the gauge be at the same height in front and behind the axel, so use the same modified legs for ALL READINGS.

David Krivoshik Elizabeth, NJ