



LOTUS EUROPA

SERVICE PARTS LIST

LOTUS CARS (SERVICE) LIMITED Norwich Norfolk, Nor. 92W England

Telephones Wymondham 3411 Cables: Lotus, Norwich Telex: 97401

Part No. 46T325 © 1966 LOTUS CARS LIMITED

CONDITIONS OF SALE AND WARRANTY

We reserve the right to make changes or improvements in the construction or equipment of our products at any time. It is our general policy, however, to supply components to the latest specification.

DELIVERY - Any date quoted for delivery is an estimate and under no circumstances shall the Company be liable for delay in delivery, howsoever occurring.

PRICE - Goods purchased will be supplied at the price ruling at the date of delivery. Lotus Cars (Service) Limited reserve the right to alter prices without previous notice, All prices are ex-Factory, packing and carriage extra.

PAYMENT - Terms of payment are strictly CASH ON DELIVERY except where credit facilities have been arranged.

PART NUMBERS - Part numbers must always be quoted on correspondence, advice notes, invoices and parts order forms.

LIABILITY - The Company's liability is limited as set out below; any implied condition or warranty is hereby excluded, and the Company will not be liable in damages for any injury or loss, damage or expense howsoever incurred or arising in connection with goods ordered hereunder.

DAMAGED PARTS - Damage to received parts should be assumed to have occurred in transit and claims should be made on the carriers and/or their insurance company. Carriage of parts returned will be at the purchaser's expense, unless previously agreed.

VARIATION - No variation of these conditions or this Warranty shall be binding on the Company unless in writing signed by a Director on behalf of the Company.

1. The Company will during the Warranty period of THREE MONTHS at their sole option, repair or replace free of charge to the purchaser any part which in their opinion is defective owing to faulty workmanship or materials; the cost of carriage and any labour costs incurred in dismantling or reassembly shall be charged to the purchaser.

2. Where the Warranty period is THREE MONTHS, the Company will within the remaining period of the original three months from the date of supply, repair or replace on the terms of the foregoing clause any part supplied under that clause which in the Company's opinion is defective owing to faulty materials or workmanship.

3. The Company's undertaking to repair or replace applies ONLY to parts of Lotus design, that is, parts manufactured by, or to the specification of one of the Lotus Group of Companies. The Company will be under no legal liability in respect of parts not of Lotus design but will, during the Warranty period, at the request of the purchaser (who shall

reimburse the Company for any expense incurred) take reasonable steps to secure the repair or replacement by the manufacturer of any such part, which may be defective.

4. Should the Company in their discretion carry out any extra work or supply any extra parts free of charge, they shall be under no legal liability of any kind in connection therewith, and the provisions of the Warranty shall not be in any way deemed to have been waived.

CLAIMS UNDER WARRANTY - Claims for the replacement of material or parts under Warranty must always be submitted to the supplying Distributor for the area concerned, All faulty material in the United Kingdom must be returned to Lotus Cars (Service) Limited. For all other territories faulty material must be held by the supplying Distributor pending settlement of the claim. The Factory will NOT accept charges for the return of such parts or the packing or crating of the same, in all cases of claims under Warranty, the decision of Lotus Cars (Service) Limited is final.

1. No claim under the Warranty will be accepted by the Company if after delivery:

- (a) Goods sold have been used in connection with motor racing or any motoring competition.
- (b) Defective parts have been altered or identification numbers removed.
- (c) Damage has occurred through mishandling or misuse.
- (d) Modifications that have been carried out on the vehicle, which are outside the specifications provided for by the Company or when genuine parts have been replaced by parts of another origin.

2. The Company may reject a claim under the Warranty unless:

- (a) Parts claimed to be defective are sent to the Company carriage paid promptly after discovery of the fault.
- (b) Parts are properly packed and labeled, with all necessary identification numbers recorded.
- (c) The purchaser furnishes full information as to the purchase of the goods and the nature of the claim.

AMENDMENTS - New or amended parts introduced subsequent to the publishing of this Parts List may be traced with the aid of the separate part number index, which will be reissued as amendments occur.

INTRODUCTION

Note: All languages other than English have been removed from this electronic document due to limitations of the OCR software used to convert from printed form. [JJ]

This document contains all the assemblies and parts sold as spares; it enables one to determine with precision their numbers and to identify them easily by the illustrations. These assemblies and these parts are set out in illustrated plates according to the unit or sub-assembly to which they belong.

A plate consists of: the illustration of parts and assemblies contained in the plate and which differ in shape; to each part shown corresponds one or several part numbers distinguished one from the other by a variant or code sign, and when necessary, tables showing additional information such as starting point, and instructions. These tables figure either at the bottom of the illustration or on a page added to the illustration.

Note: The meaning of the code signs and expressions used on each plate, is indicated on ~~plate n° vi ix~~. [See "Conventional Signs And Expressions" – JJ]

An index to the plates, in front of the latter, gives the relationship between their numbers and their technical descriptions.

A numerical index at the end of the catalogue gives the relationship between the part numbers and the plate numbers, also the quantity of parts per vehicle in the plate under consideration, except for the numbers of standard nuts and bolts. Bulletin 1967/16 gives the meaning of the code numbers of standard nuts and bolts.

USE

Ascertaining a part number knowing the nature of this part:

1. In the plate index, find the plate corresponding to the unit or sub-assembly to which this part may be attached.
2. Consult the catalogue to find this plate, when necessary taking into account the starting point or the variant distinguishing this plate.
3. Having found the plate, look for the illustration of the desired part. One or several numbers correspond to this illustration; choose the suitable number, taking into account code signs or expressions, which distinguish them.

The numerical or alphabetical reference marks added to the part number, ensure the connection between these numbers and the additional information appertaining to them, included In the tables found at the bottom of the illustration or on the additional page.

Checking by Branches, Distributors or Importation Centres of an Order Form, which has been filled in by an Agent or by a client using the documents in his possession.

1. In the numerical index, at the part number indicated on the order form, find the corresponding plate numbers.
2. Examine these plates to check that the part number given is correct taking into account the starting points added to this number and the number of the vehicle or unit for which the part has been ordered.

Identifying by the illustration a part the number of which is known.

1. In the numerical index, at the given part number, find the corresponding plate numbers.
2. Consult these plates.

Conventional Signs And Expressions

+	Use up stock.
⊠	After exhaustion of stock, supply.
👁️	"See plate" or "see page".
↗️	For.
↘️	Except.
👉	L.H. drive.
👈	R.H. drive.
➡️ to
&	And.
🗉	Numbers of vehicles or units in question symbolised by.
🔊	High pitch.
🔇	Low pitch.
①	1st speed.
②	2nd speed.
③	3rd speed.
④	4th speed.
①-②	1st and 2nd speeds.
②-③	2nd and 3rd speeds.
③-④	3rd and 4th speeds.
.../00	Equipment Version Number
BP	Gearbox-differential.
C	Colour.
D	Right hand.

DE	Outside diameter.
DI	Inside diameter.
E	Thickness.
F	Felt.
G	Left hand.
GE	Weight in grammes.
H	Overall height.
LA	Total width.
LO	Total length.
M	Carpeting.
MOT	Engine.
N	Number of teeth.
NP	Number of parts.
OC	Calibrated orifice.
R	Reverse.
T	Cloth.
V	Volts.
VADM	Sold by the decimetre (3.937 in.)
VAM	Sold by the metre (3.28 ft.)
VB	Grained vinyl sheet.
VEH	Vehicle.
VEN LO	Sold in fixed length.

LOTUS NORWICH, ENGLAND

LISTE N°	LIBR. N°
FRANCKISSON N°	

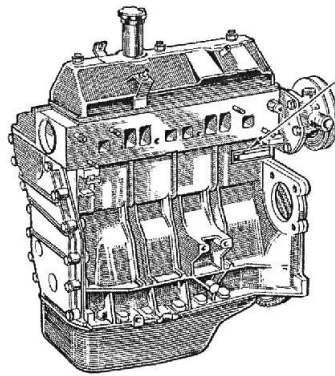
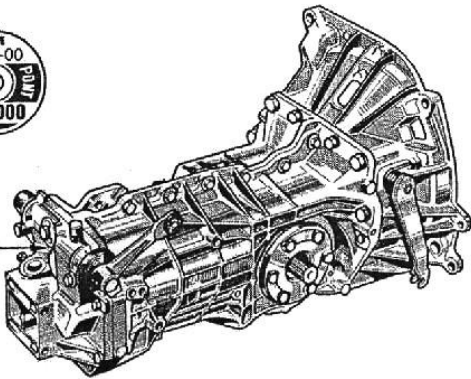
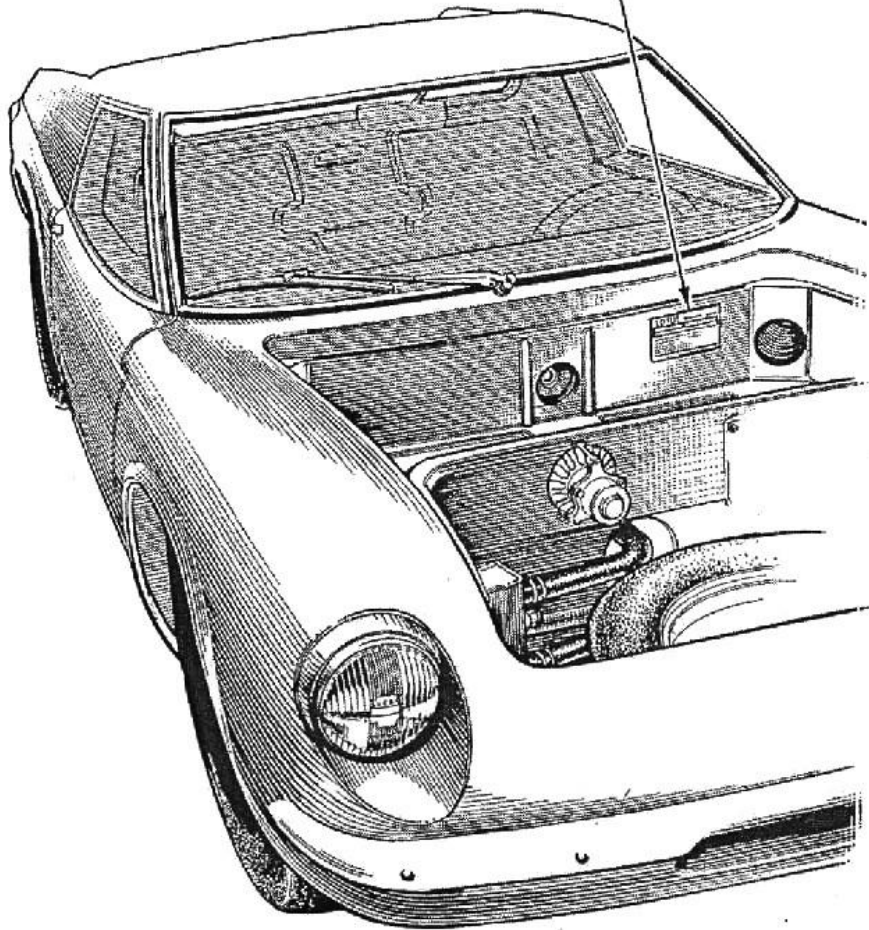

MOTELI 171-20
171-20
MOTELUR

