

CONTENTS OF CHAPTER

	Page
I - IDENTIFICATION	3
II - SPECIFICATIONS	3
III - CROSS SECTIONS	4
IV - REMOVING, OVERHAULING AND REFITTING THE CLUTCH	4
A/ Removing	
B/ Checking	
C/ Replacing the flywheel	
D/ Refitting	
V - REPLACING THE CLUTCH SHAFT BEARING	6
VI - REPLACING THE CLUTCH SHAFT SEAL	6
VII - ADJUSTING THE CLUTCH CLEARANCE	7
VIII - REPLACING THE CLUTCH WITHDRAWAL PAD	9
IX - REMOVING AND REFITTING THE CLUTCH CABLE	10
X - REMOVING AND REFITTING THE CLUTCH PEDAL	11

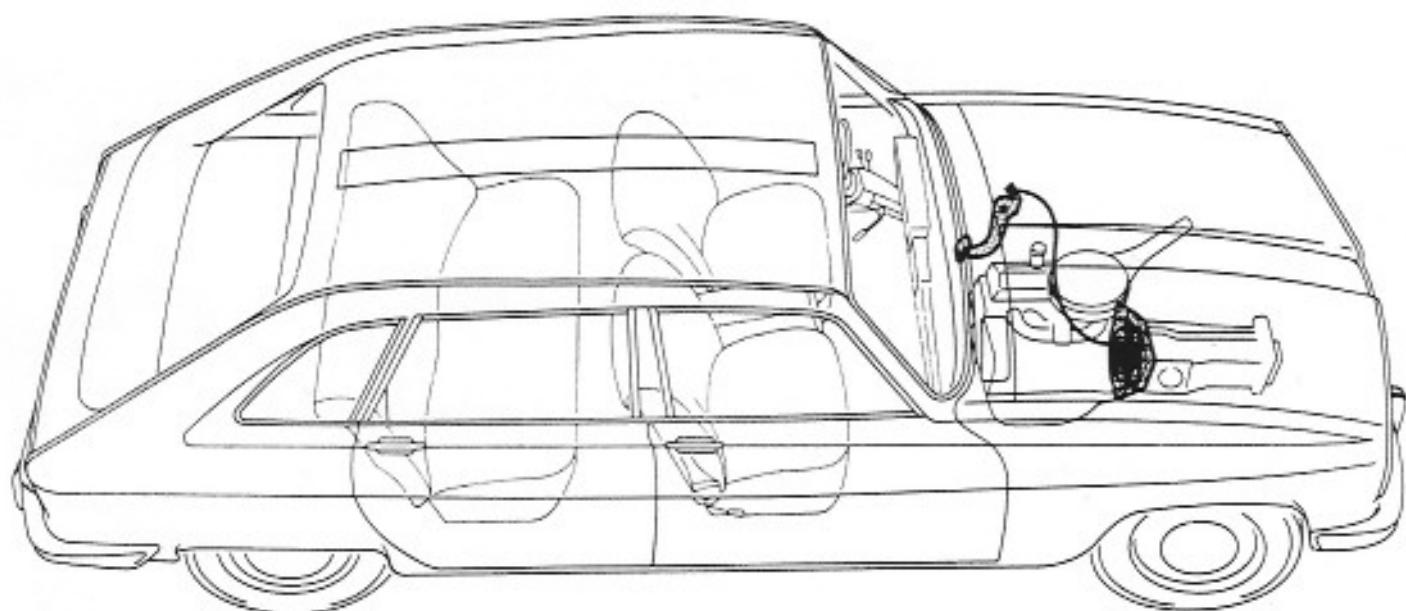
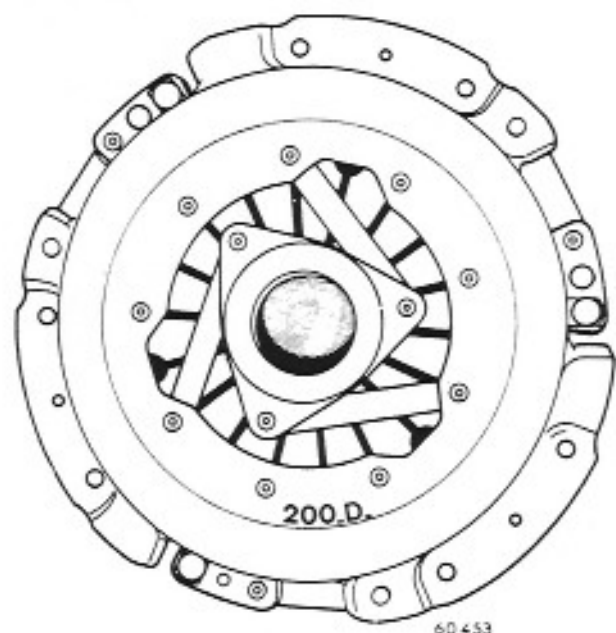

66953

I - IDENTIFICATIONII - SPECIFICATIONS

60453

The type number is stamped on the front face of the plate : 200 D.

Single disc clutch operating dry.
 Elastic hub clutch friction disc.
 Thickness of disc : 7.7 mm (.304")
 Ball bearing withdrawal pad.
 Diaphragm spring clutch plate.
 Clutch clearance measured at the end of the lever : 2 to 3 mm (5/64 to 1/8")

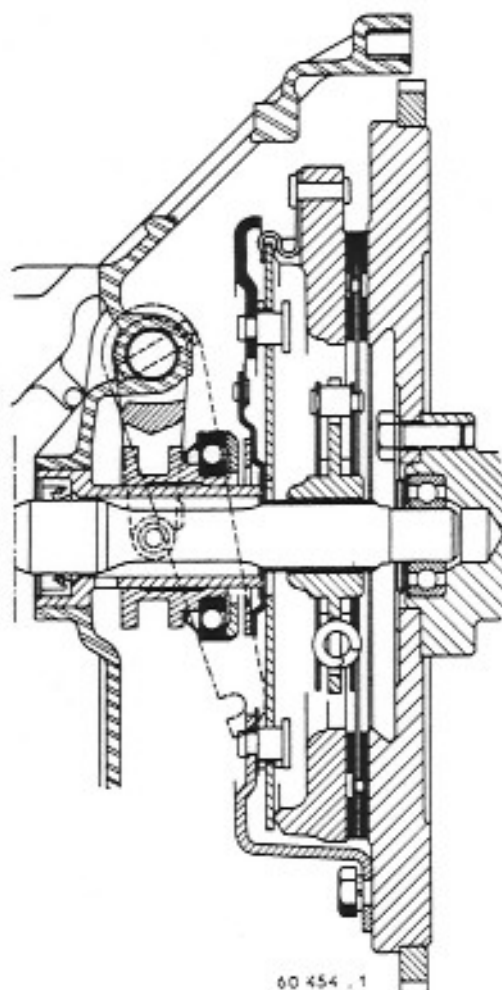
III - CROSS SECTION

60 454 . 1

IV - REMOVING, OVERHAULING AND REFITTING THE CLUTCH

A/ REMOVING

Remove the gearbox (see chapter E - Gearbox).
Mark the position of the clutch mechanism with
reference to the flywheel.

Remove the clutch mechanism securing bolts.
Remove the clutch mechanism and the friction
disc.

B/ CHECKING

Check all the parts.
Replace any defective parts.

Refacing the clutch friction face on
the flywheel is not possible.

The flywheel is to be replaced if this face is
damaged.

Check to ensure that there is an 8 mm (.315")
diameter hole at the bottom of the withdrawal
pad guide.

If there is not, drill one as shown on page 6.

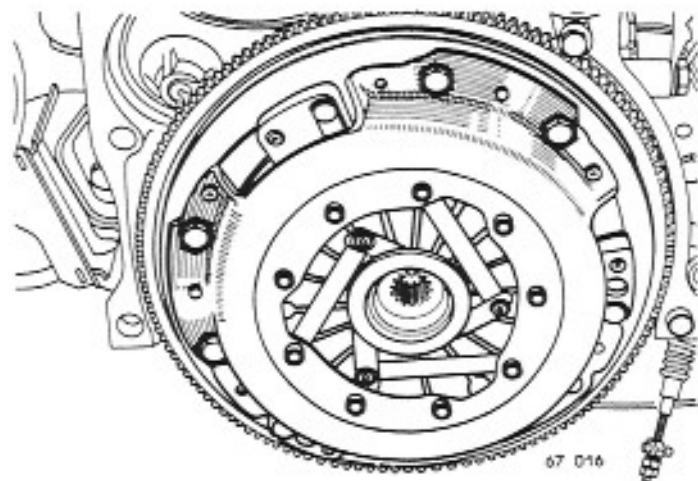

67 016

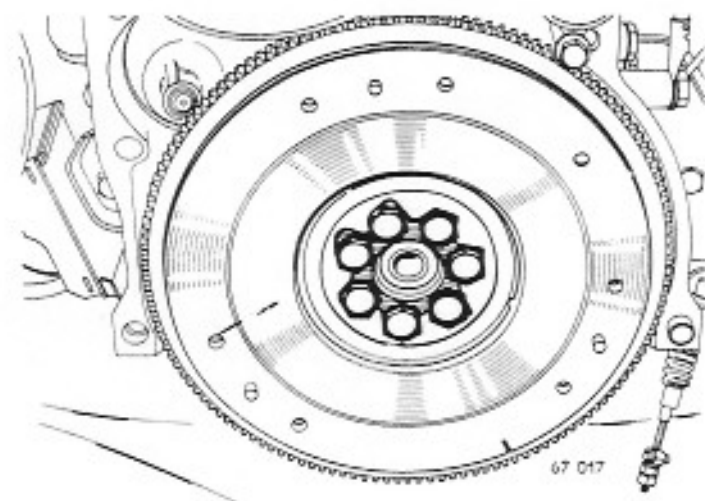
C/ REPLACING THE FLYWHEEL

The number of bolts which secure the flywheel to the crankshaft has been increased from 5 to 7.

1/ Removing

Unlock and remove the securing bolts.
Remove the flywheel.

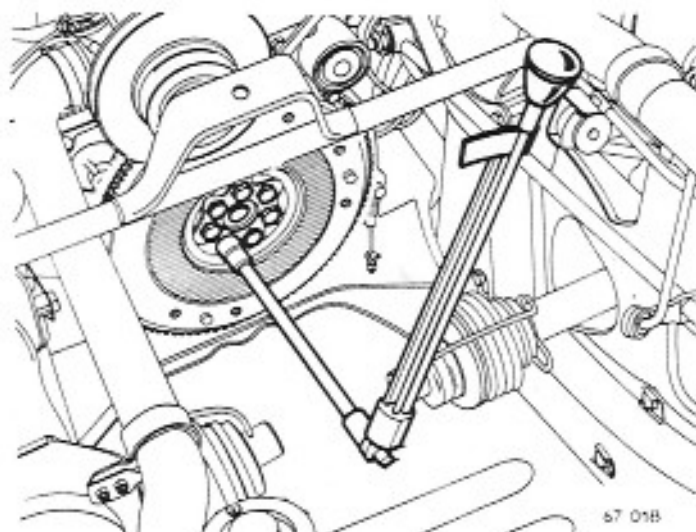
2/ Refitting

Clean the flywheel securing holes in the crankshaft by means of a dry cloth.

Degrease the face on which the flywheel is located on the crankshaft.

Degrease the flywheel securing bolts.

Apply one or two drops of "Loctite Frein Filet Faible" locking compound on the bolts.

Fit the flywheel and secure it by means of new self locking bolts.

Tighten the bolts to 5 m.da N (40 lb/ft) using torque wrench Mot.50.

Fold up the locking plate with a pair of pliers.
Fold it onto one of the flats on each bolt only.

D/ REFITTING

Degrease the flywheel friction face.

Fit the disc with the off-set on the hub towards the gearbox (transmission case).

Position the clutch mechanism by means of the position mark made during dismantling, when applicable.

Centralize the disc by means of mandrel Emb.257.

Slowly screw in the bolts which secure the mechanism and then finally tighten them.

Refit the gearbox (transmission case).

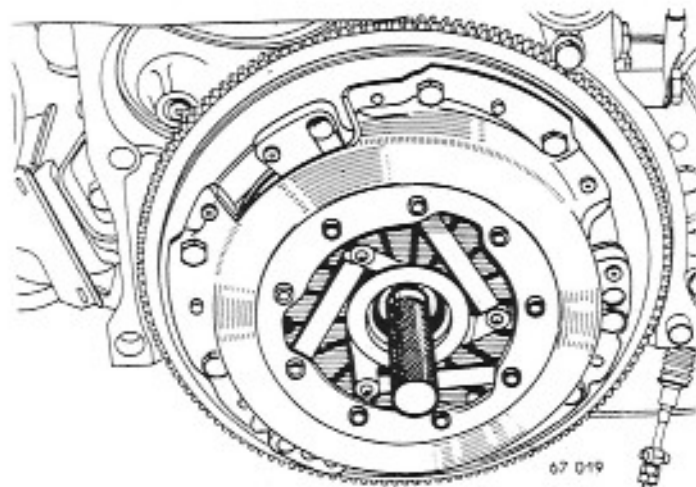

V - REPLACING THE CLUTCH SHAFT BEARING

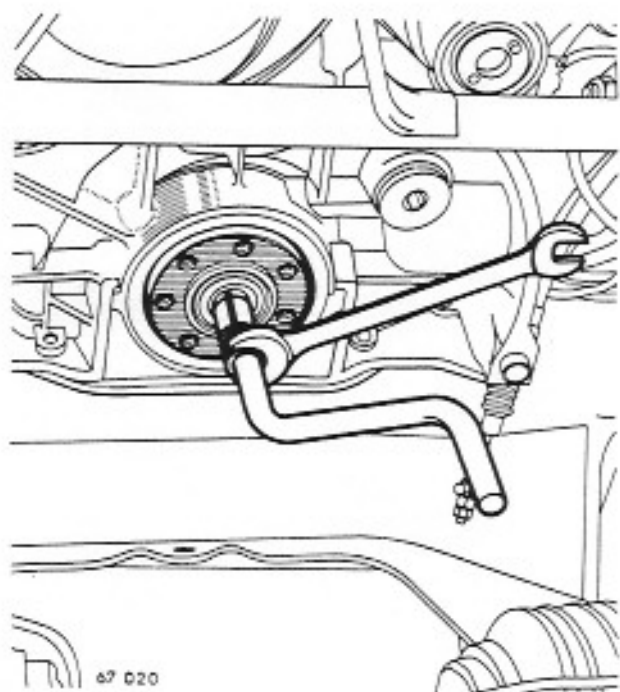

Remove the gearbox (transmission case) (see chapter E - Gearbox).

Remove :

- the clutch mechanism and friction disc,
- the flywheel.

Extract the bearing by means of extractor Mot. 11
Fit the new bearing with the seal facing towards the outside.

NOTE - The bearing is supplied pregreased and is therefore not to be cleaned.

Refit :

- the flywheel,
- the clutch friction disc and mechanism,
- the gearbox (transmission case).

VI - REPLACING THE SEAL ON THE CLUTCH SHAFT

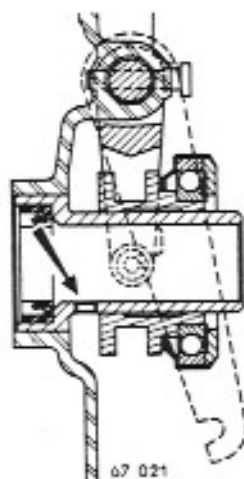

Remove the gearbox (transmission case) (see chapter E - Gearbox).

Separate the clutch housing from the gearbox (transmission case).

Remove the seal.

Check to see whether there is a hole 8 mm (.315") in diameter at the bottom of the withdrawal pad guide.

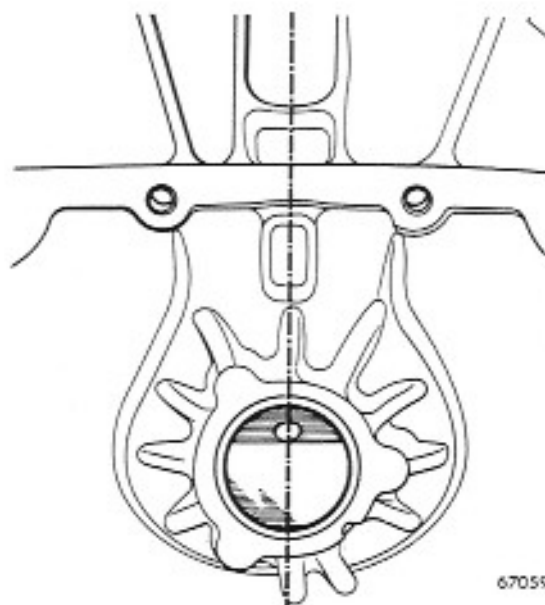

If there is no hole, drill one as follows :

- Place tool Emb. 387 inside the guide.
- Place the thrust washer in position and screw up the retaining nut.
- Position the centre of the hole in the tool on the vertical centre line of the clutch housing and tighten the nut.

- Move the clutch withdrawal pad as far as it will go forward and hold it in position by means of a spacer.
- Slowly drill the hole with a 7 mm (.276") diameter drill.
- Remove the tool and carefully remove the burrs from the edges of the hole.
- Fit the new seal with its lip towards the gear-box.

- Fit the clutch housing to the gearbox paying attention not to damage the lip on the seal as it passes over the splines.

To do this, wrap adhesive plastic tape round the splines.

Refit the gearbox (transmission case).

VII - ADJUSTING THE CLUTCH CLEARANCE

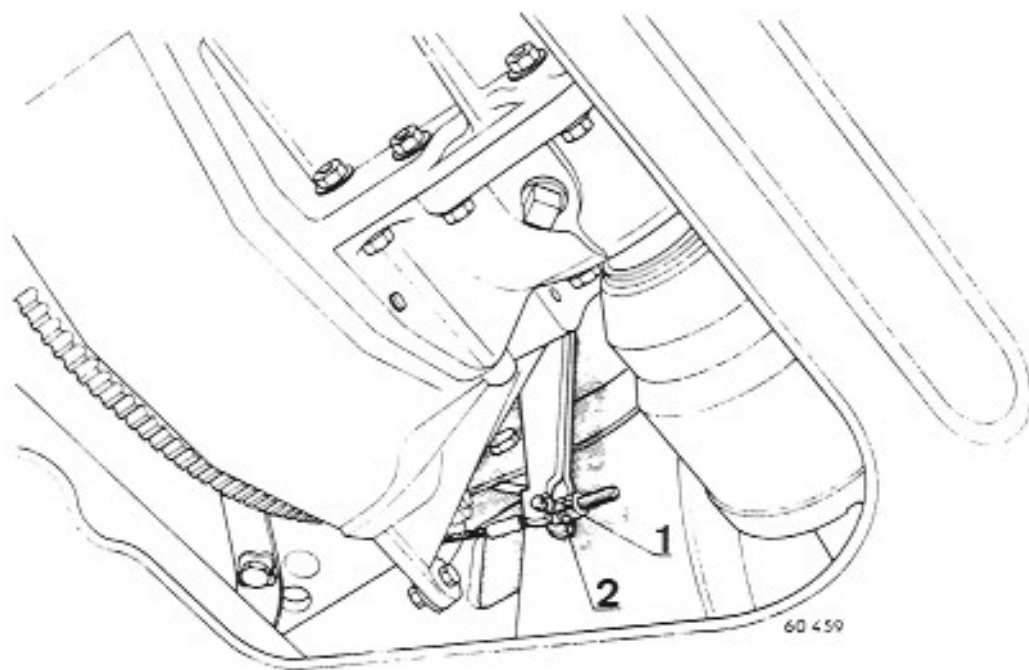

Loosen lock-nut (1).

Screw nut (2) in or out to obtain a clearance of : 2 to 3 mm (5/64 to 1/8") at the end of the lever.

Tighten the lock-nut.

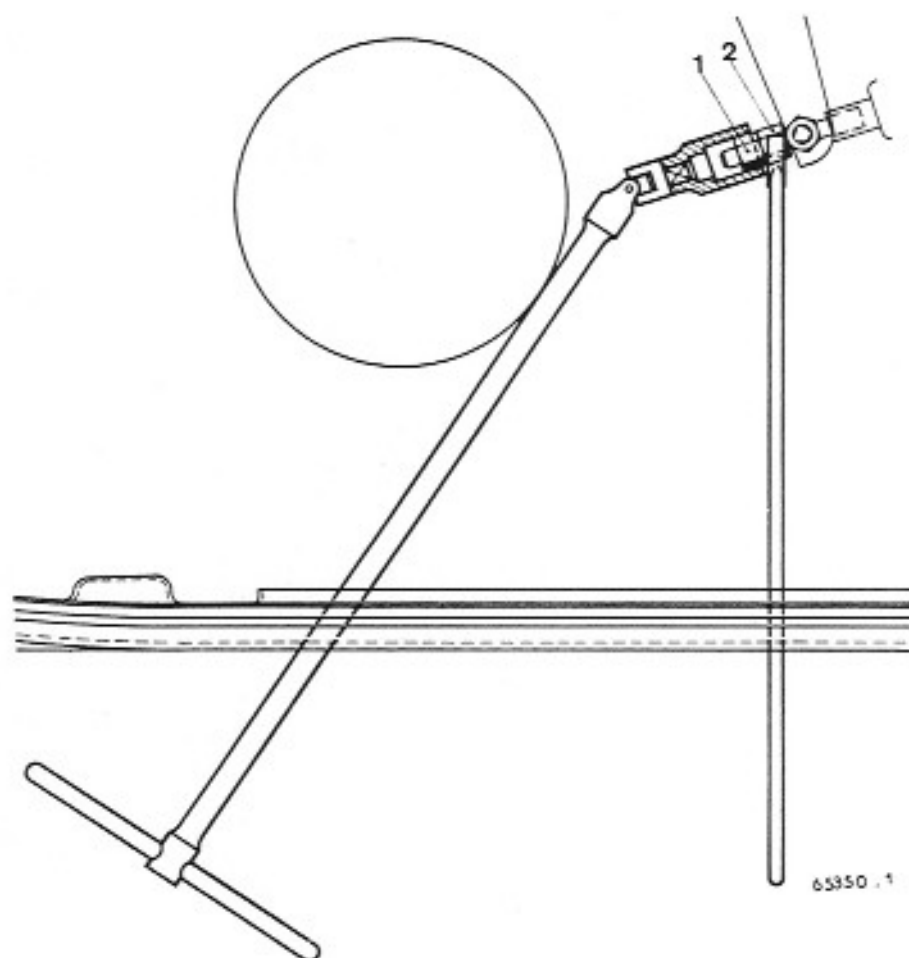

Certain vehicles are equipped with a protective engine undertray. On these the operation is to be carried out as follows :

- Place open ended spanner (wrench) Emb. 389 on nut (2).
- Loosen the lock-nut by means of knuckle spanner Emb. 388.

- Remove the open ended spanner (wrench) and push the knuckle spanner (wrench) over both nuts.

- Screw them in or out until the correct clearance of : 2 to 3 mm (5/65 to 1/8") at the end of the lever is obtained.
- Tighten lock-nut (1) while holding open ended spanner (wrench) on nut (2).

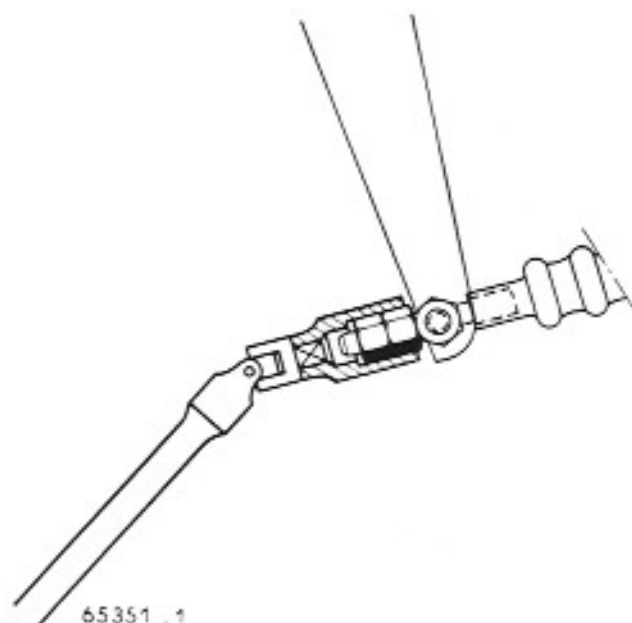

VIII - REPLACING THE CLUTCH WITHDRAWAL PAD.

B



A

65 690

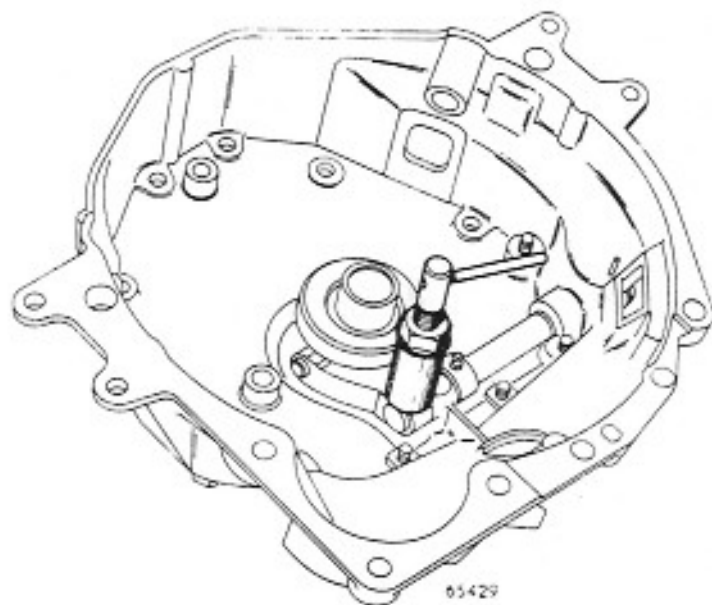

65429

Remove the gearbox (transmission case) (see chapter E - Gearbox).

Remove the fork retaining pins by means of :

- tool Emb.322 for cylindrical pins A.
- tool Emb.384 for splined pins B.

Swing the withdrawal fork and remove the withdrawal pad.

Grease the withdrawal pad guide by means of MOLYKOTE "BR 2" grease (ref. 806 377).

Fit the new withdrawal pad.

Align the holes in the withdrawal fork with that in its shaft.

Fit the pins : Leave the correct projection D with reference to the withdrawal fork
 $D = 1 \text{ mm } (1/32")$.

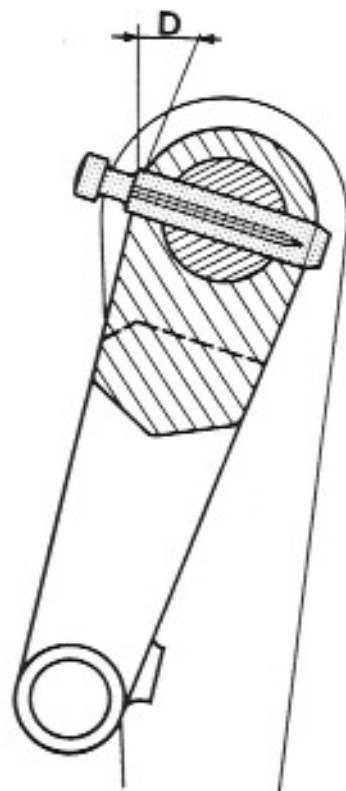

65 691

NOTE : Only fit splined pins B under repair.
 Refit the gearbox (transmission case).

IX - REMOVING AND REFITTING THE CLUTCH CABLE

A/ REMOVING

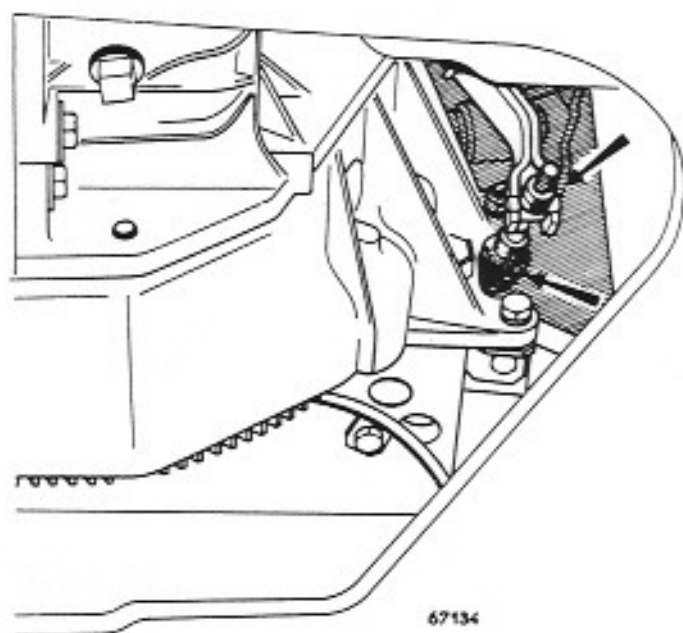

Disconnect the cable at the clutch withdrawal lever.
Remove the rubber protective cap and push out the cable end fitting from its clamp.

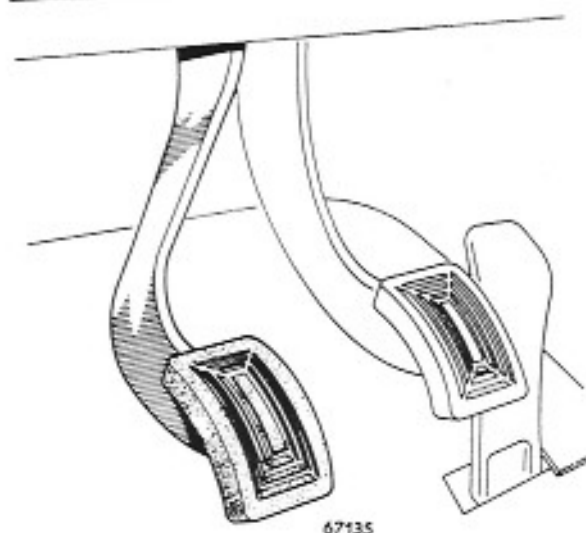

Remove the glove compartment on the left hand side.
Unhook the pedal return spring.
Remove the pedal retaining clip and free it from its shaft.
Disconnect the cable from the pedal and remove it.

B/ REFITTING

Carry out the removing operations in reverse.
Apply compound at the point where the cable passes through the scuttle.
Adjust the clutch clearance.

X - REMOVING AND REFITTING THE CLUTCH CABLE.

A/ REMOVING

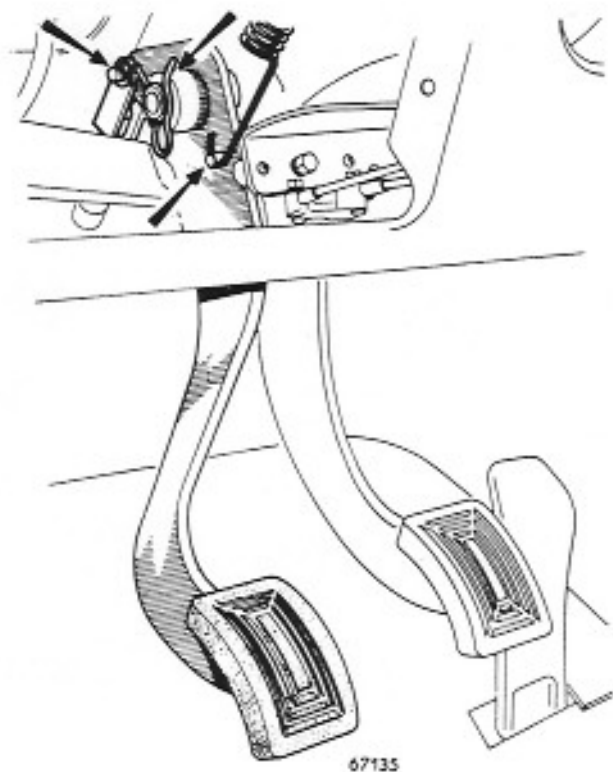

- Remove the glove compartment on the left hand side.
- Unhook the pedal return spring.
- Remove the pedal retaining clip and free it from its shaft.
- Disconnect the cable from the pedal.

B/ REFITTING

- Carry out the removing operations in reverse.
- Check the clutch clearance.