

ITEM	SPECIFICATION	QTY	DESCRIPTION	MANUF
1	FF ASSY	1	FRAME FRAME ASSY	REINFORCED
2	FC-P1	1	FRAME CENTRE - PART	AS LOTUS, NOT COMPLETED
3	FC-P2	1	FRAME CENTER- RIGHT	SEE FC-P1
4	FR-FL	1	FRAME REAR - FRONT LEFT	AS LOTUS
5	FR-RL	1	FRAME REAR - REAR LEFT	AS LOTUS
6	FR-FR	1	FRAME REAR - FRONT RIGHT	SEE FR-FL
7	FR-RR	1	FRAME REAR - REAR RIGHT	SEE FR-RL
8	FR-P1L	1	FRAME REAR - PART 1 LEFT	AS LOTUS
9	FR-P1R	1	FRAME REAR - PART 1 RIGHT	SEE FR-P1L
10	FRAMEBRACE	1	FRAME BRACE	REINFORCED
11	054A0701 frame pl thread	2	HRSB 1/4" x 1 1/4" x 1 1/2"	.

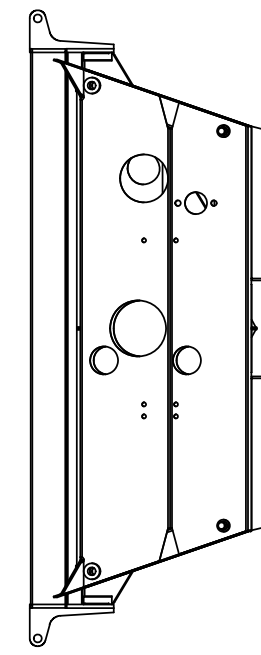

PARTIAL DRAWING:  
 TRANSMISSION END SUPPORT MISSING (DIFFERENT DESIGN IN MY APPLICATION)  
 ENGINE MOUNT HOLES MISSING (NIT USED IN MY APPLICATION)  
 RIDIUS ARM MOUNTING HOLE (DIFFERENTE DESIGN IN MY APPLICATION)

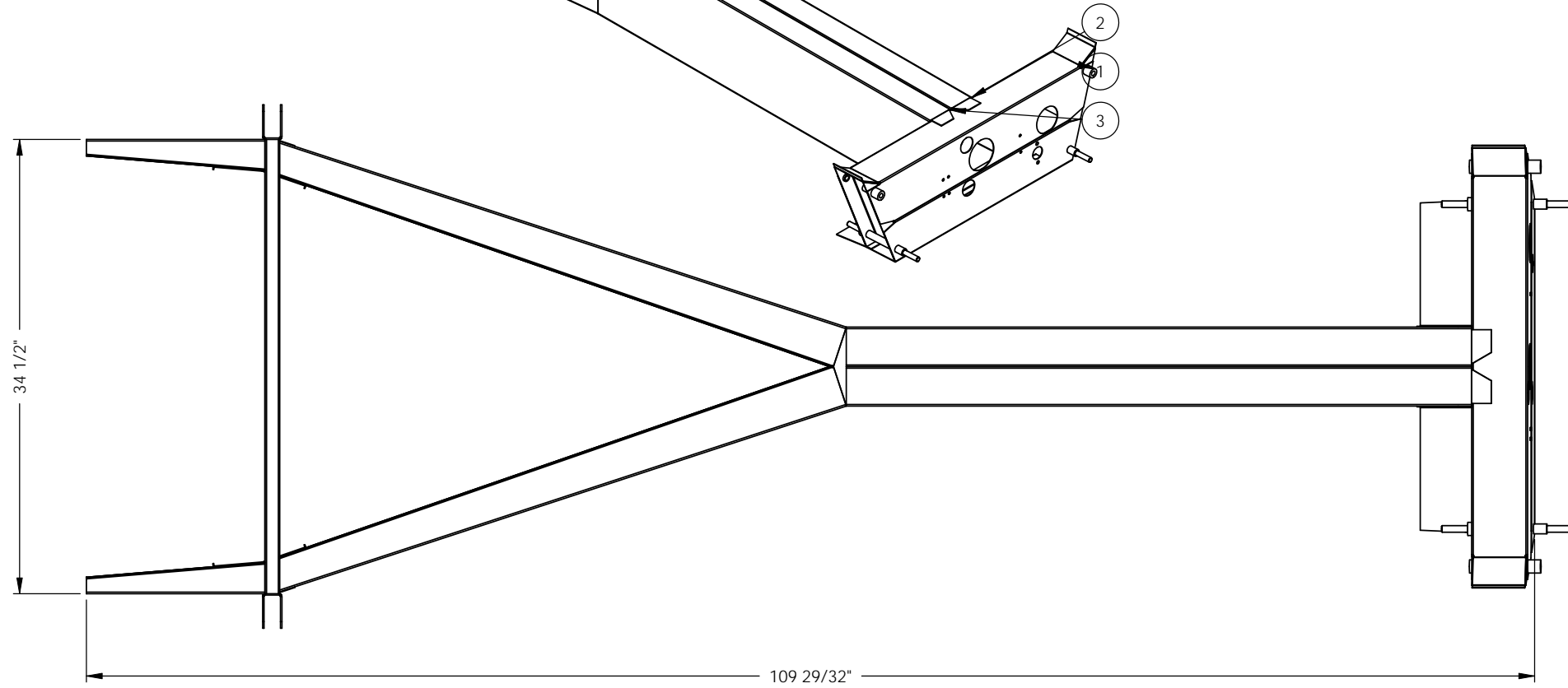
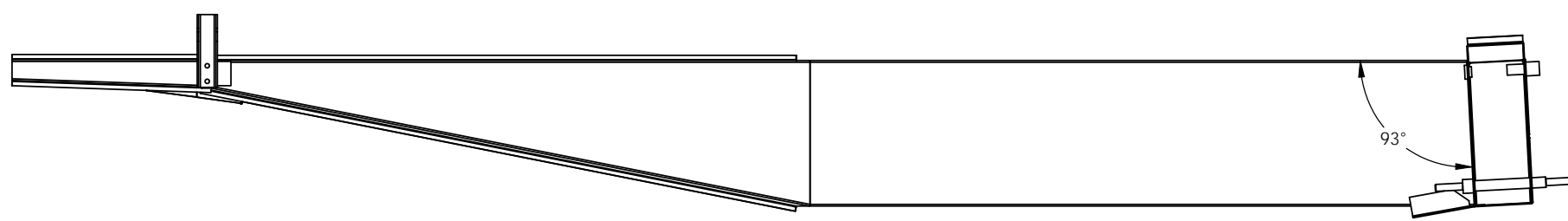

NET WEIGHT / POIDS NET:

REVISION	DESCRIPTION	DATE	BY/PAR

**TOLERANCE UNLESS SPECIFIED**  
**TOLERANCES SI NON SPECIFIEES**  
 DIMENSIONS IN INCHES  
 DIMENSIONS EN POUCHES

1/X : ±1/64 MACHINING  
 .XX : ±.010 USINAGE  
 .XXX : ±.003

< 60° ±1/16 WELDING,  
 ≥ 60° ±3/8 DRILLING  
 ANGLE: ±1/2° SOUDURE,  
 PERÇAGE

DRAWN BY / DESSIN PAR		DATE	TITLE / TITRE	
APPROVED / APPROUVE	DATE	SCALE / ECH. 1:12	FORMAT B	REVISION 0
DRAWING NO. / NO. DESSIN			PAGE 1/1	
<b>FRAME ASSY</b>				

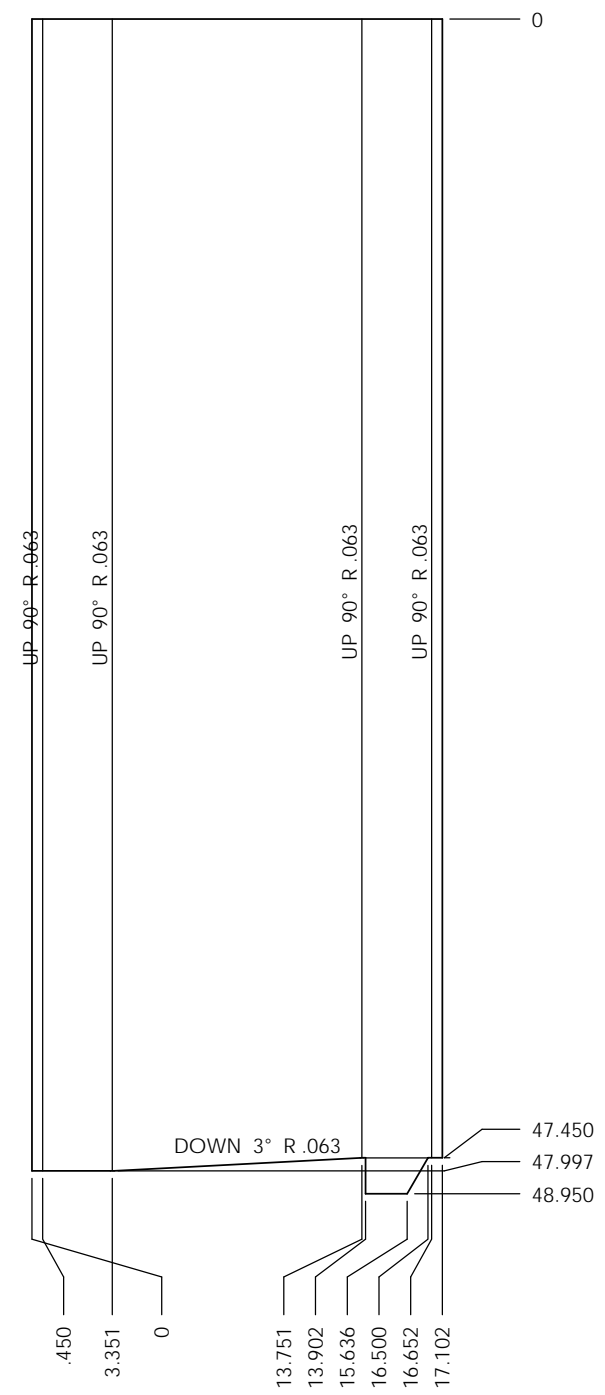
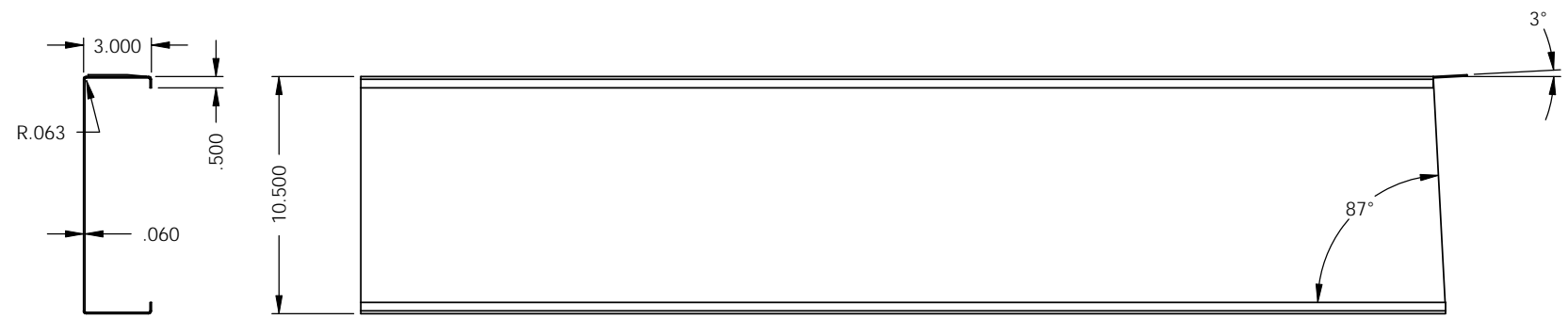
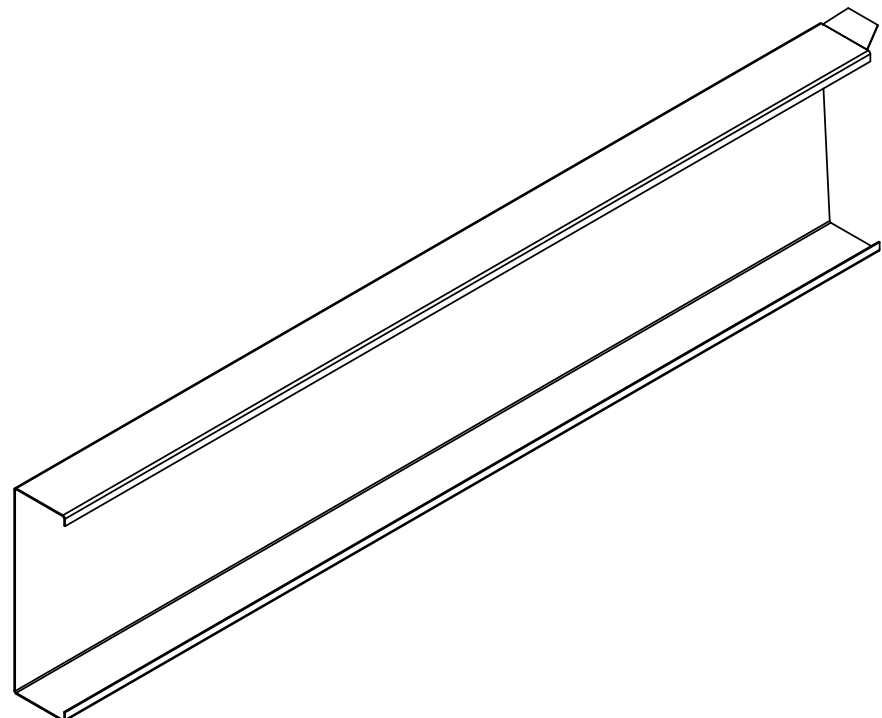

NET WEIGHT / POIDS NET:

REVISION	DESCRIPTION	DATE	BY/PAR

**TOLERANCE UNLESS SPECIFIED  
TOLERANCES SI NON SPECIFIEES**  
DIMENSIONS IN INCHES  
DIMENSIONS EN POUCES

1/X : ±1/64 MACHINING  
.XX : ±.010 USAGE  
.XXX : ±.003

< 60° ±1/16 WELDING,  
≥ 60° ±3/8 DRILLING  
ANGLE: ±1/2° SOLDERING,  
PERÇAGE

DRAWN BY / DESSIN PAR		DATE	
APPROVED / APPROUVE		DATE	

TITLE / TITRE FRAME CENTRE - PART			
	SCALE / ÉCH. 1:8	FORMAT <b>B</b>	REVISION <b>0</b>
DRAWING NO. / NO. DESSIN <b>FC-P1</b>			PAGE 1/1

ITEM	SPECIFICATION	QTY	DESCRIPTION	MANUF
1	FF-P1	1	FRAME FRONT - PART	AS LOTUS W REINFORCEMENT
2	FF-P2	1	FRAME FRONT - PART 2	AS LOTUS
3	FF-P3	2	FRAME FRONT - P3	AS LOTUS
4	FF-P4	2	FRAME FRONT - AXLE	AS LOTUS W REINFORCEMENT
5	FF-P5	2	FRAME FRONT - SPACER	REINFORCED
6	PP-F6	2	FRAME FRONT - SHORT SPACER	REINFORCED
7	FF-P7	2	FRAME FRONT - PART 7	AS LOTUS

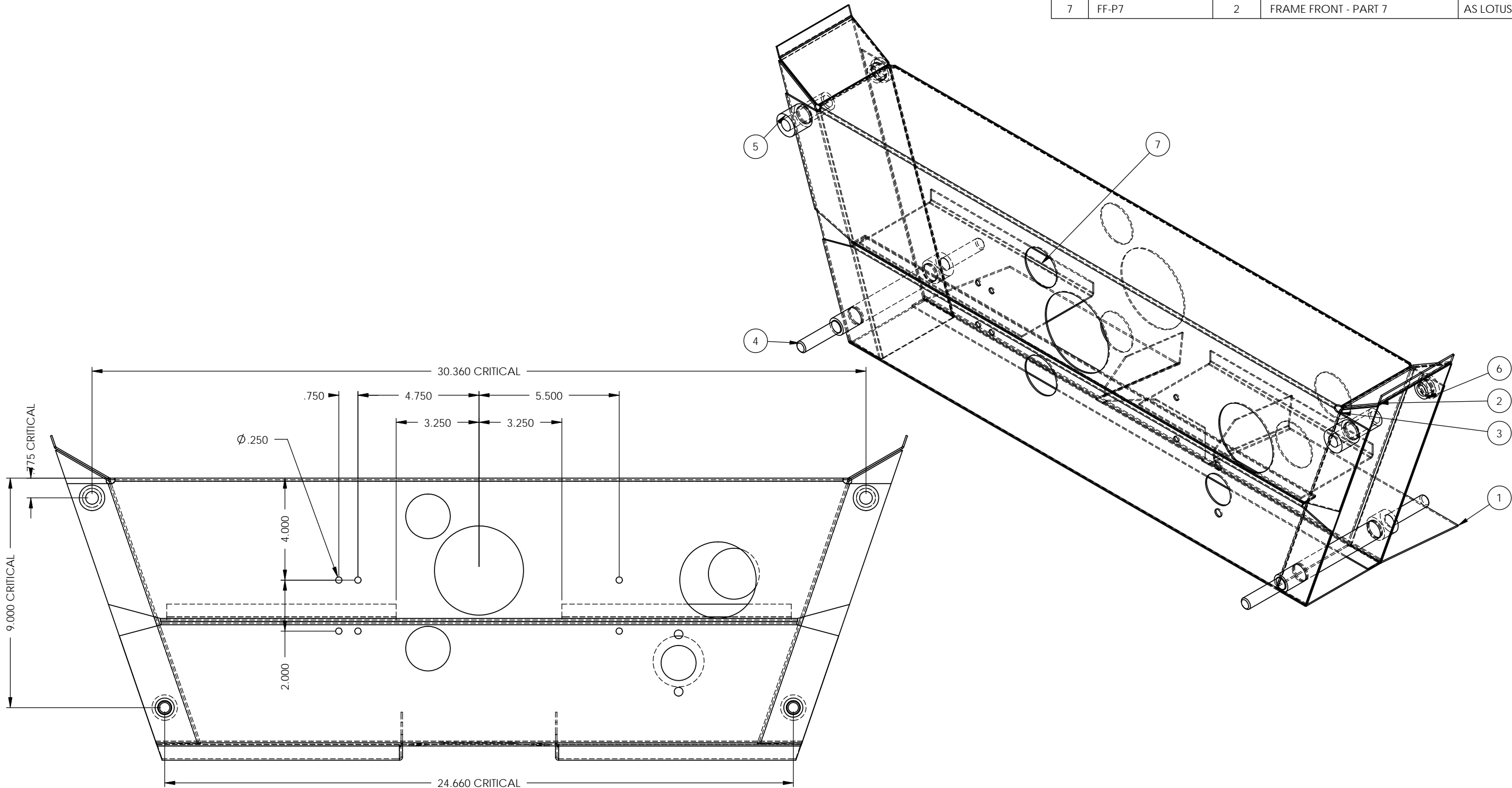

NET WEIGHT / POIDS NET:

REVISION	DESCRIPTION	DATE	BY/PAR

**TOLERANCE UNLESS SPECIFIED**  
**TOLERANCES SI NON SPECIFIEES**  
 DIMENSIONS IN INCHES  
 DIMENSIONS EN POUCHES

1/X : ±1/64 MACHINING  
 .XX : ±.010 USINAGE  
 .XXX : ±.003

< 60° ±1/16 WELDING,  
 ≥ 60° ±3/8 DRILLING,  
 ANGLE: ±1/2° SOLDERING,  
 PERÇAGE PERÇAGE

TITLE / TITRE			
FRAME FRAME ASSY			
DRAWN BY / DESSIN PAR	DATE	SCALE / ECH.	FORMAT
		1:4	B
APPROVED / APPROUVE	DATE	DRAWING NO. / NO. DESSIN	REVISION
		FF ASSY	0
			PAGE
			1/1

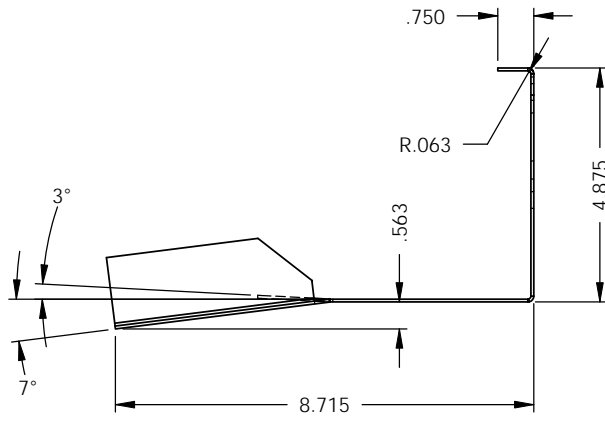
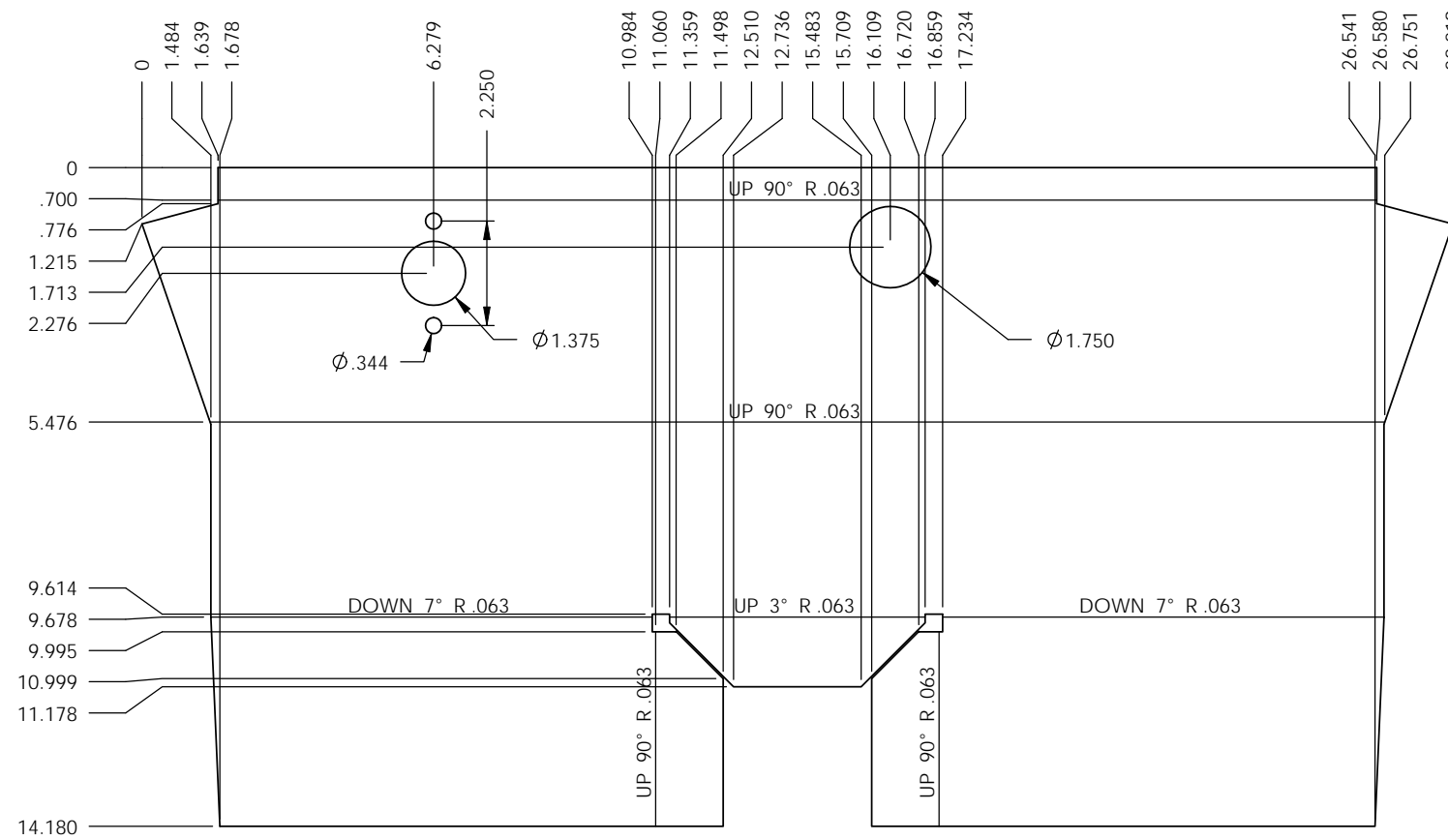
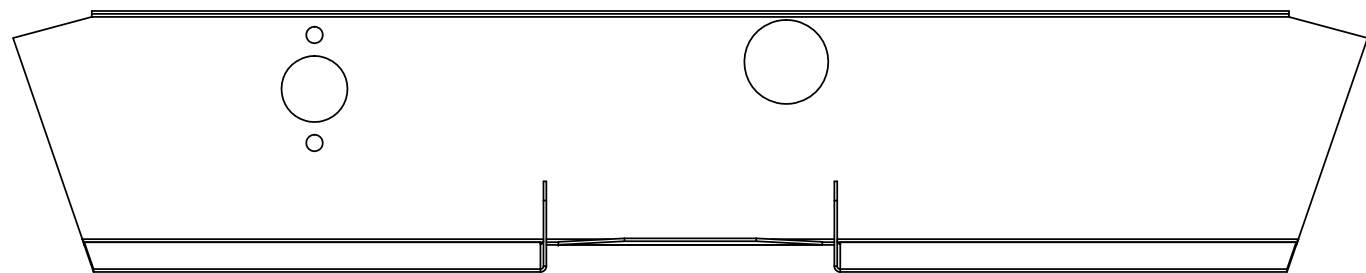
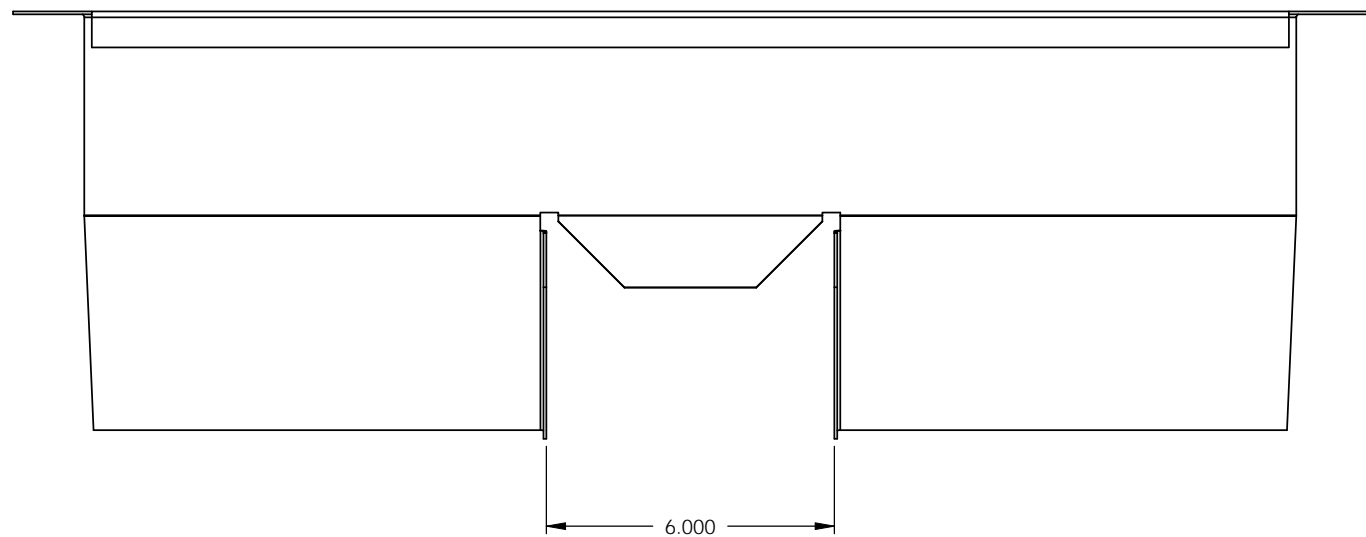

NET WEIGHT / POIDS NET:

REVISION	DESCRIPTION	DATE	BY/PAR

**TOLERANCE UNLESS SPECIFIED**  
**TOLERANCES SI NON SPECIFIEES**  
 DIMENSIONS IN INCHES  
 DIMENSIONS EN POUCHES

1/X : ±1/64 MACHINING  
 .XX : ±.010 USINAGE  
 .XXX : ±.003

< 60° ±1/16 WELDING,  
 ≥ 60° ±3/8 DRILLING  
 ANGLE: ±1/2° Soudure,  
 Percage

DRAWN BY / DESSIN PAR		DATE
APPROVED / APPROUVE		DATE

TITLE / TITRE  
**FRAME FRONT - PART**

SCALE / ECH. **1:4**    FORMAT **B**    REVISION **0**

DRAWING NO. / NO. DESSIN **PP-F1**    PAGE **1/1**

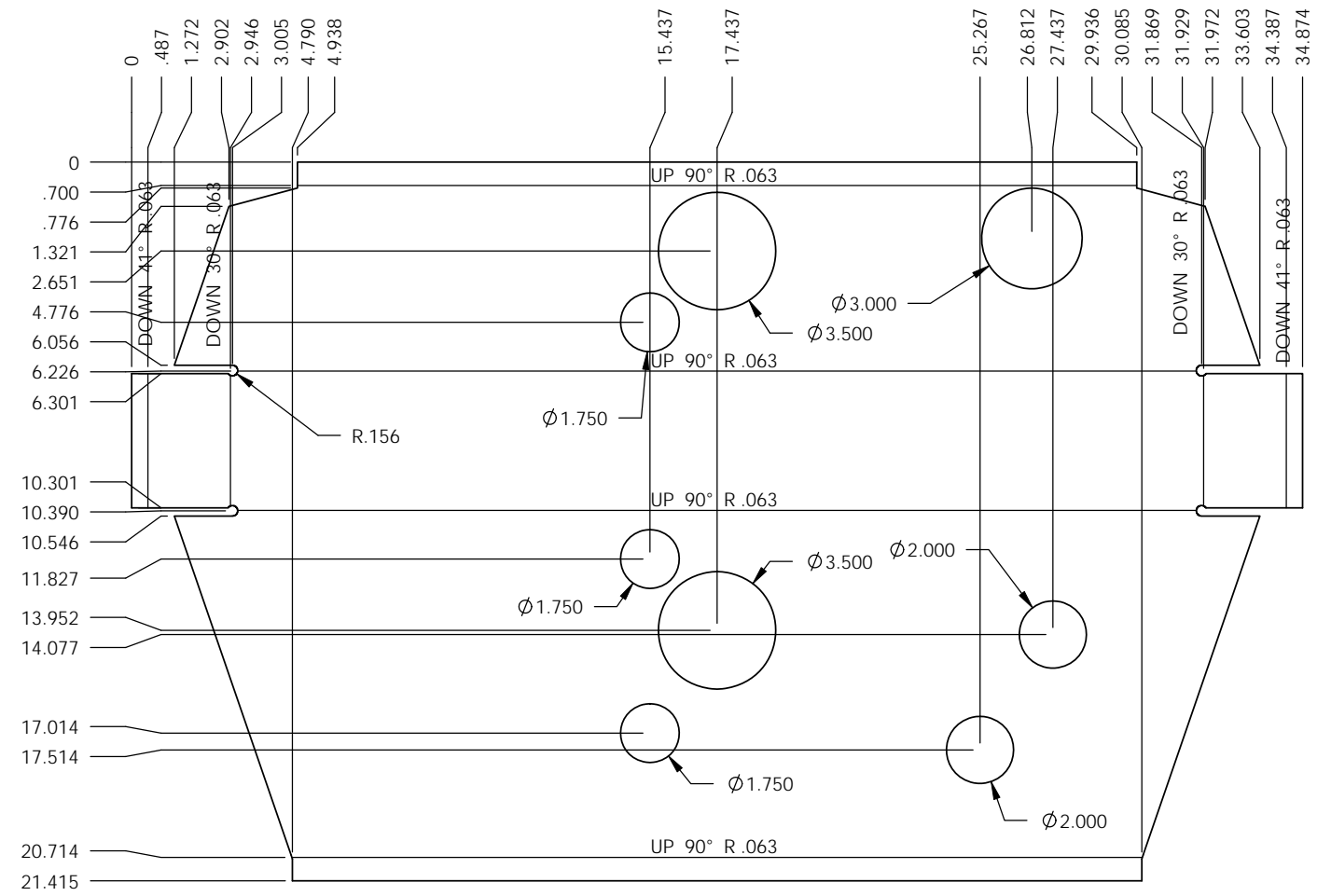
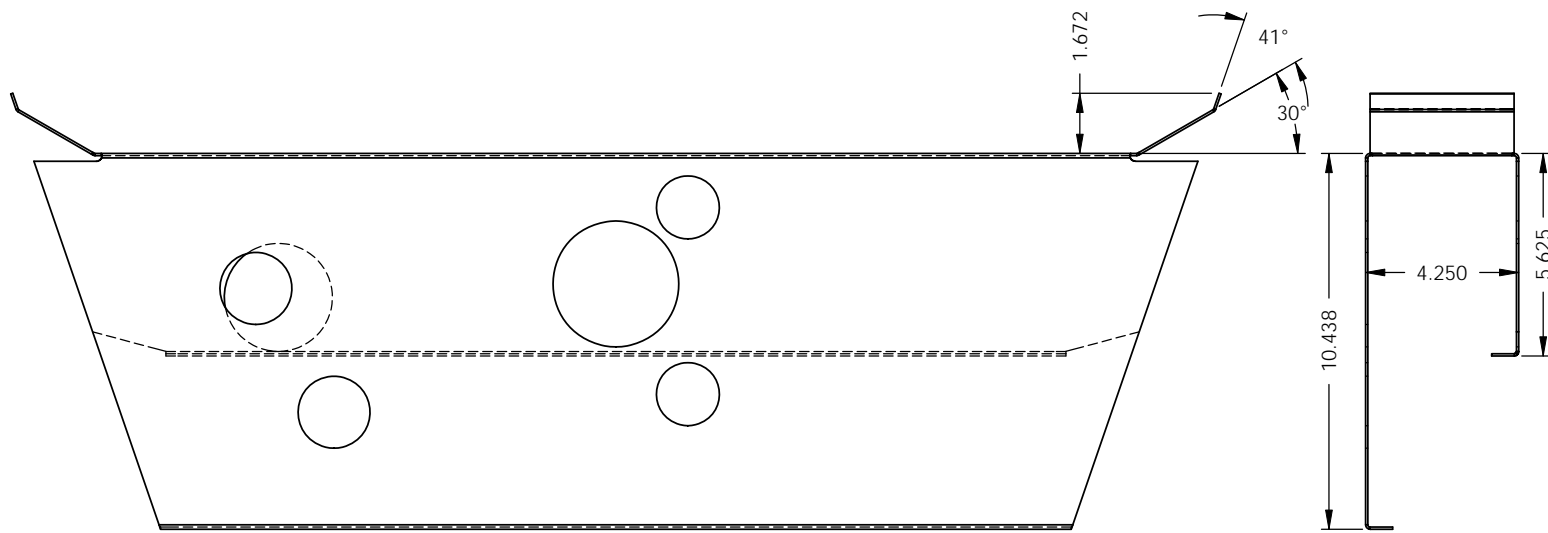
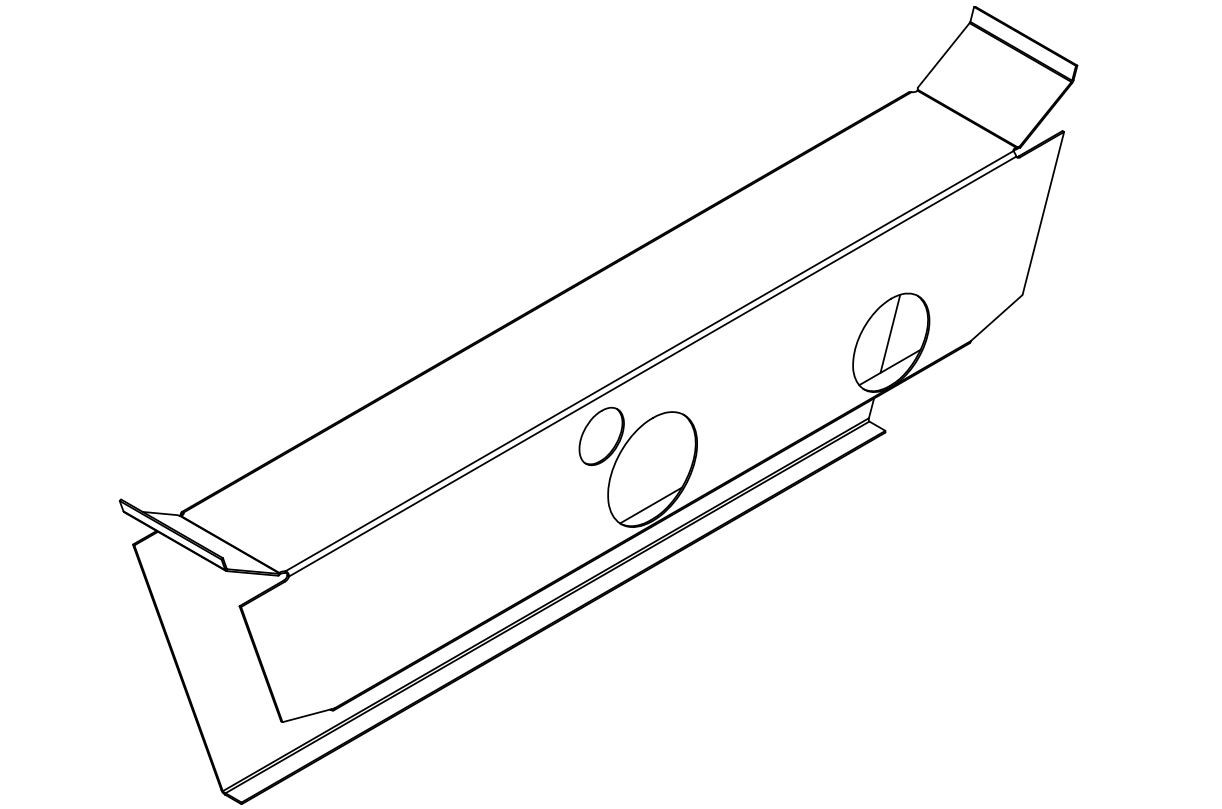

NET WEIGHT / POIDS NET:

REVISION	DESCRIPTION	DATE	BY/PAR

**TOLERANCE UNLESS SPECIFIED**  
**TOLERANCES SI NON SPECIFIEES**  
 DIMENSIONS IN INCHES  
 DIMENSIONS EN POUCES

1/X : ±1/64 MACHINING  
 .XX : ±.010 USINAGE  
 .XXX : ±.003

< 60° ±1/16 WELDING,  
 ≥ 60° ±3/8 DRILLING,  
 ANGLE: ±1/2° SOLDERING,  
 PERÇAGE PERÇAGE

DRAWN BY / DESSIN PAR		DATE
APPROVED / APPROUVE		DATE

TITLE / TITRE			
FRAME FRONT - PART 2			
SCALE / ÉCH.	FORMAT	REVISION	
3:16	B	0	
DRAWING NO. / NO. DESSIN			PAGE
FF-P2			1/1

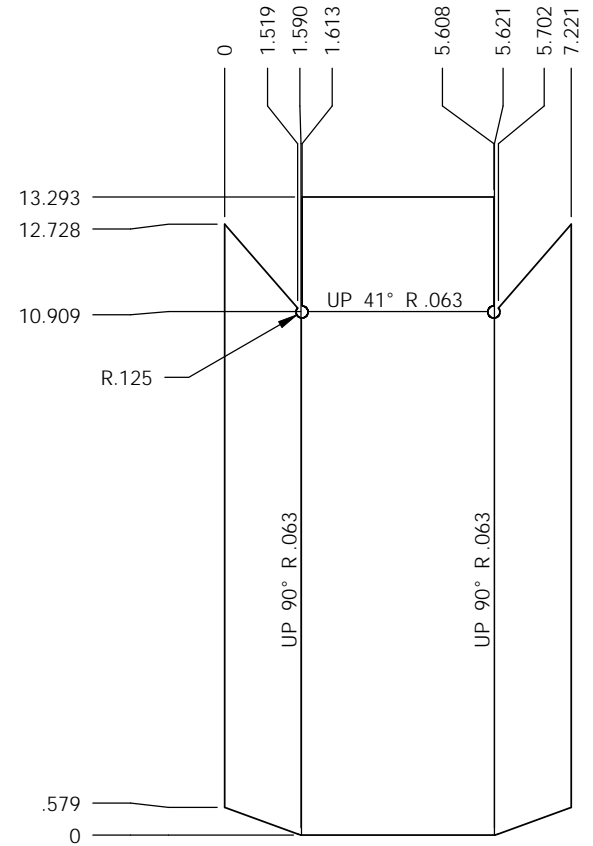
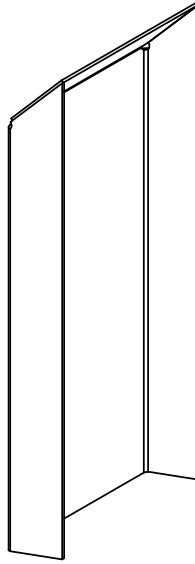
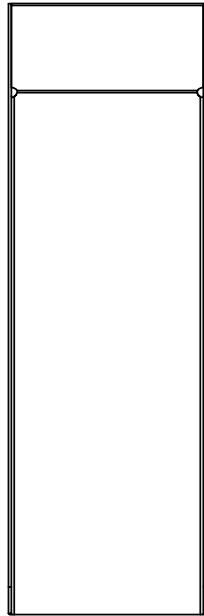
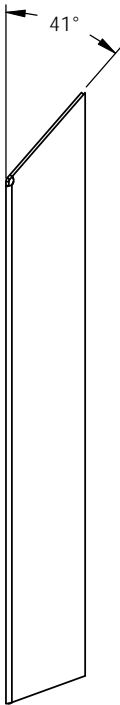
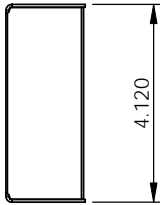

NET WEIGHT / POIDS NET:

REVISION	DESCRIPTION	DATE	BY/PAR

**TOLERANCE UNLESS SPECIFIED**  
**TOLERANCES SI NON SPECIFIEES**  
 DIMENSIONS IN INCHES  
 DIMENSIONS EN POUCES

1/X :	±1/64	MACHINING
.XX :	±.010	USINAGE
.XXX :	±.003	63

< 60°      ±1/16      WELDING,  
 ≥ 60°      ±3/8      DRILLING  
 ANGLE:    ±1/2°      SOUDURE,  
    PERCEGE

DRAWN BY / DESSIN PAR		DATE		TITLE / TITRE <b>FRAME FRONT - P3</b>		
				SCALE / ECH. <b>1:4</b>	FORMAT <b>A</b>	REVISION <b>0</b>
APPROVED / APPROUVE		DATE		DRAWING NO. / NO. DESSIN <b>FF-P3</b>		
				PAGE <b>1/1</b>		

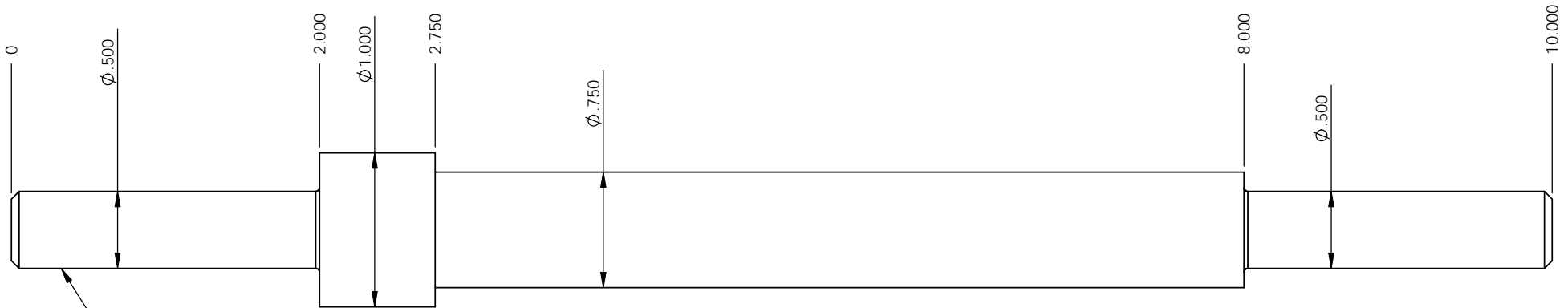

1/2-20 NF BOTH END, SEE WITH SUSPENSION BUSHING

NET WEIGHT / POIDS NET:

REVISION	DESCRIPTION	DATE	BY/PAR

**TOLERANCE UNLESS SPECIFIED**  
**TOLERANCES SI NON SPECIFIEES**  
**DIMENSIONS IN INCHES**  
**DIMENSIONS EN POUCES**

1/X : ±1/64  
 .XX : ±.010  
 .XXX : ±.003

MACHINING  
 USINAGE  
 63/

< 60" ±1/16  
 ≥ 60" ±3/8  
 ANGLE: ±1/2°

WELDING,  
 DRILLING  
 SOUDURE,  
 PERÇAGE

DRAWN BY / DESSIN PAR		DATE
APPROVED / APPROUVE		DATE

TITLE / TITRE			
FRAME FRONT - AXLE			
DRAWING NO. / NO. DESSIN	SCALE / ECH.	FORMAT	REVISION
FF-P4	1:1	A	0
PAGE			1/1

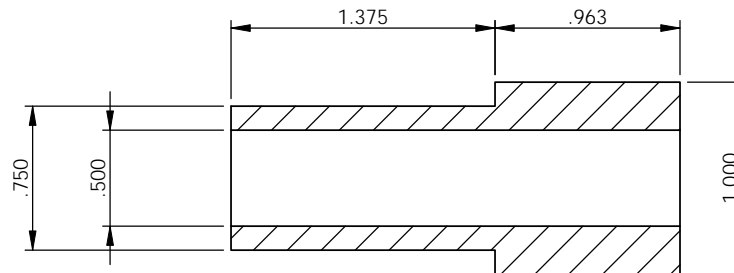
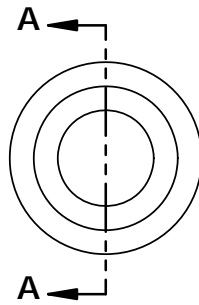

SECTION A-A

NET WEIGHT / POIDS NET:

REVISION	DESCRIPTION	DATE	BY/PAR

**TOLERANCE UNLESS SPECIFIED  
TOLERANCES SI NON SPECIFIEES**  
DIMENSIONS IN INCHES  
DIMENSIONS EN POUCES

1/X :	±1/64	MACHINING
.XX :	±.010	USINAGE
.XXX :	±.003	

< 60° ±1/16 WELDING,  
≥ 60° ±3/8 DRILLING,  
ANGLE: ±1/2° SOUDURE,  
PERCEUSE

	DRAWN BY / DESSIN PAR	DATE	
	APPROVED / APPROUVE	DATE	

TITLE / TITRE			
FRAME FRONT - SPACER			
	SCALE / ECH. 1:1	FORMAT <b>A</b>	REVISION <b>0</b>
DRAWING NO. / NO. DESSIN <b>PP-F5</b>			PAGE 1/1









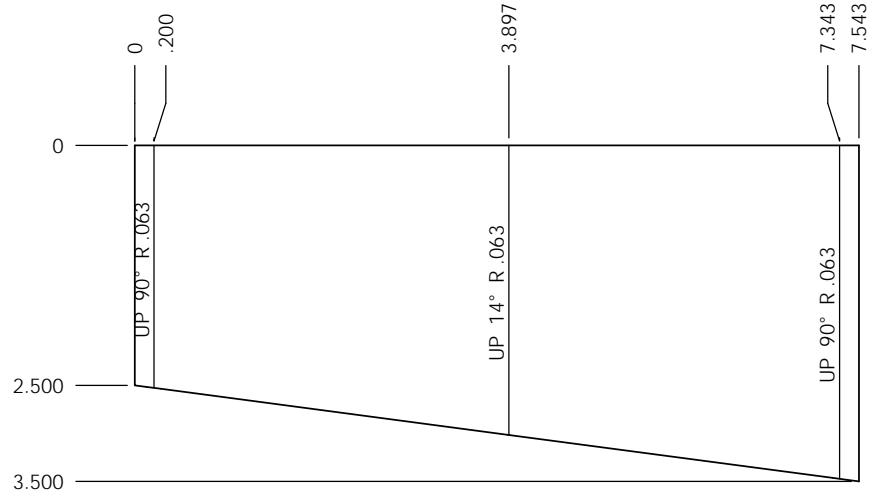
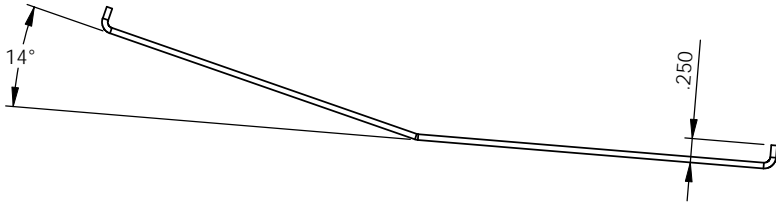
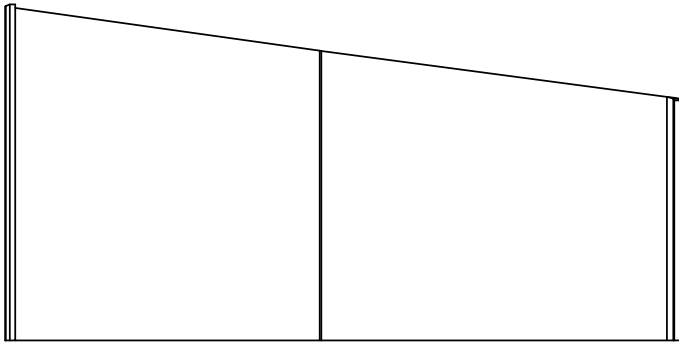

NET WEIGHT / POIDS NET:

REVISION	DESCRIPTION	DATE	BY/PAR

**TOLERANCE UNLESS SPECIFIED  
TOLERANCES SI NON SPECIFIEES**  
DIMENSIONS IN INCHES  
DIMENSIONS EN POUCES

1/X :	±1/64	MACHINING
.XX :	±.010	USINAGE
.XXX :	±.003	63

< 60" ±1/16 WELDING,  
≥ 60" ±3/8 DRILLING,  
ANGLE: ±1/2° SOUDURE,  
PERCEGE

DRAWN BY / DESSIN PAR	DATE	
APPROVED / APPROUVE	DATE	

TITLE / TITRE			
FRAME REAR - PART 1 LEFT			
SCALE / ECH.	FORMAT	REVISION	
1:2	A	0	
DRAWING NO. / NO. DESSIN			PAGE
FR-P1L			1/1

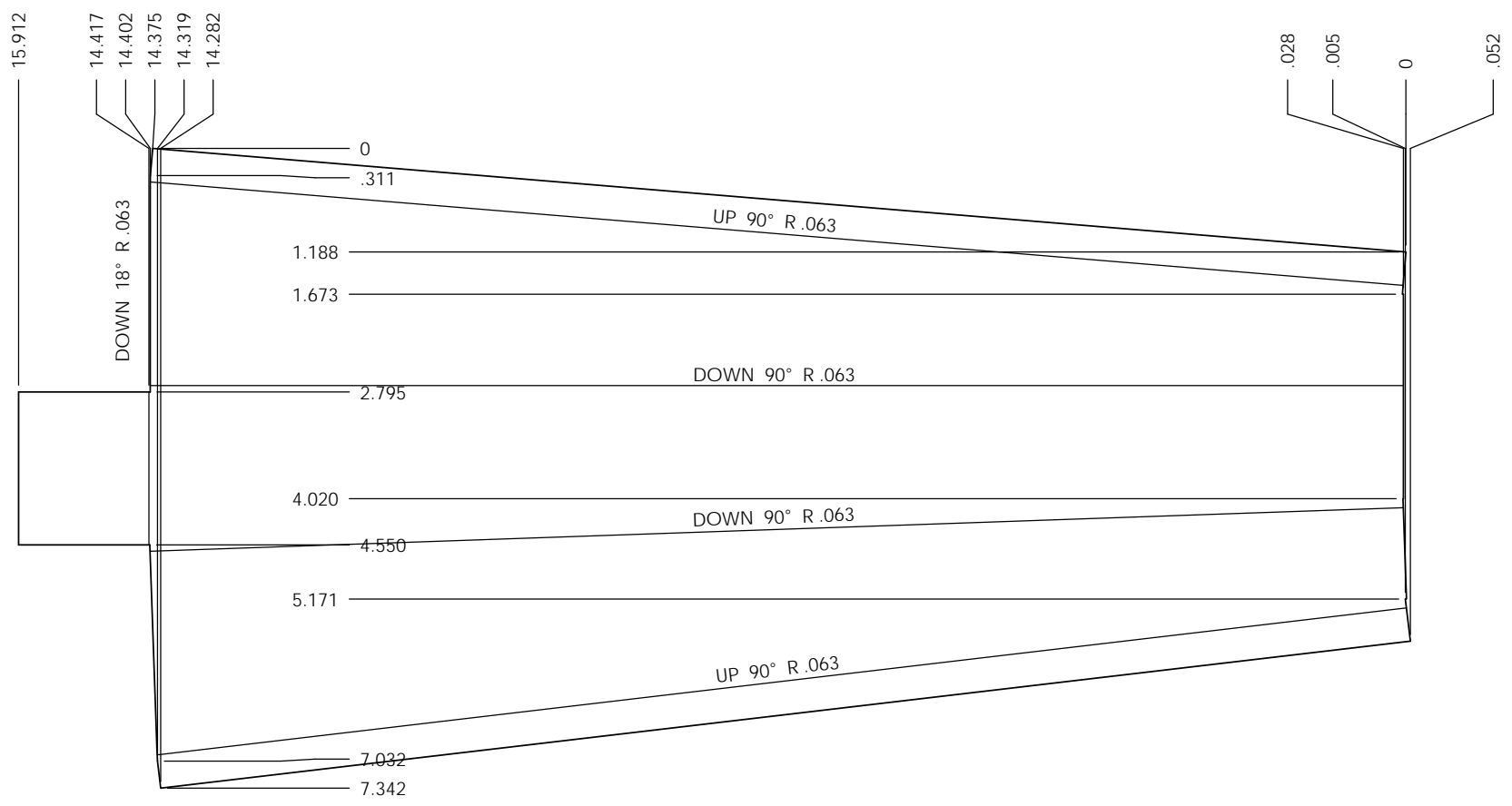
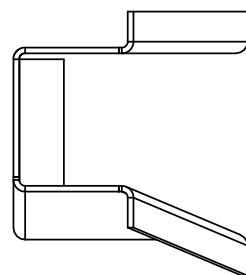
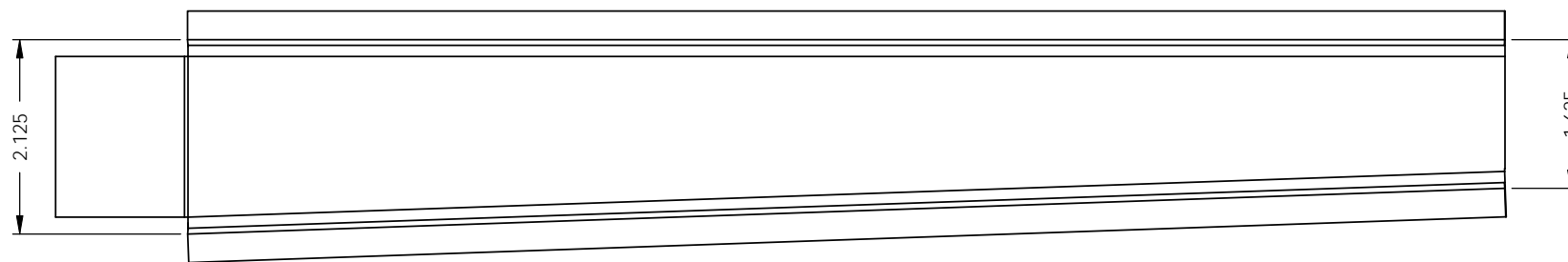
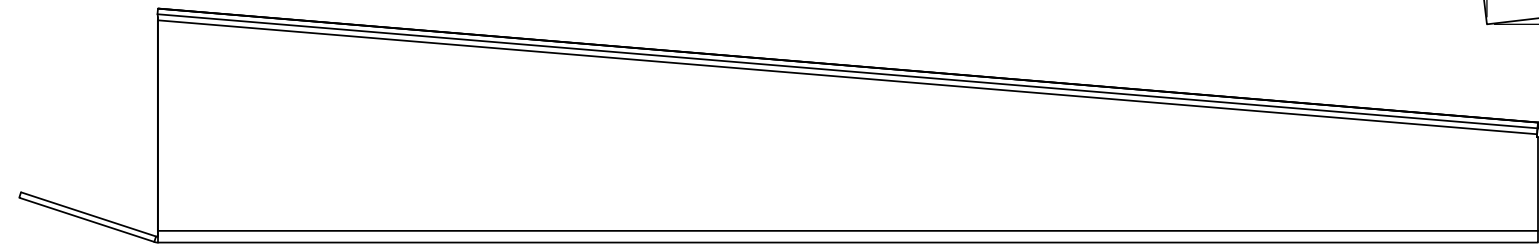
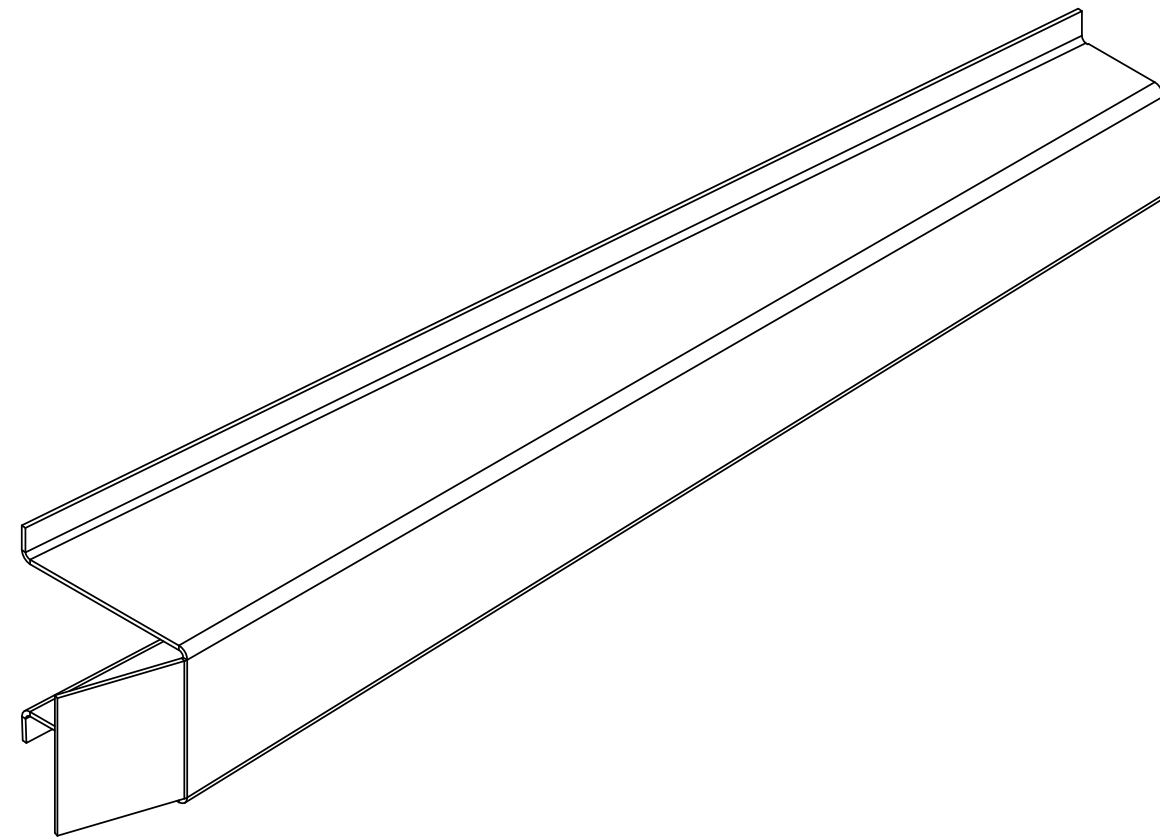

NET WEIGHT / POIDS NET:

REVISION	DESCRIPTION	DATE	BY/PAR

**TOLERANCE UNLESS SPECIFIED**  
**TOLERANCES SI NON SPECIFIEES**  
 DIMENSIONS IN INCHES  
 DIMENSIONS EN POUCES

1/X : ±1/64 MACHINING  
 .XX : ±.010 USINAGE  
 .XXX : ±.003

< 60° ±1/16 WELDING,  
 ≥ 60° ±3/8 DRILLING,  
 ANGLE: ±1/2° SOLDERING,  
 PERÇAGE PERÇAGE

DRAWN BY / DESSIN PAR		DATE
APPROVED / APPROUVE		DATE

TITLE / TITRE			
FRAME REAR - REAR LEFT			
SCALE / ÉCH. 1:2	FORMAT <b>B</b>	REVISION <b>0</b>	
DRAWING NO. / NO. DESSIN <b>FR-RL</b>		PAGE 1/1	